



**BS EN 598 Ductile Iron All Socket Fitting With Flexible Joint. (For Sewerage)**

**BS EN 598**

**全疏杰柔性膠圈接頭球墨鑄鐵排污配件**

45°Bend 90°Bend & 90°Long Radius Bend



**祥興鑄鐵有限公司**

**CHEUNG HING FOUNDRY (HK) LIMITED**



# BS EN 598 Ductile Iron All Socket Fitting With Flexible Joint. (For Sewerage)

## BS EN 598

### 全疏杰柔性膠圈接頭球墨鑄鐵排污配件

#### 90° Bend

#### 90° 邊

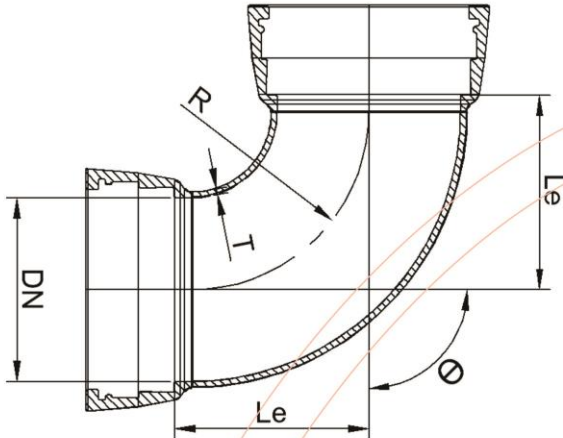

#### 90° Bend with Access door

#### 90° 正口邊

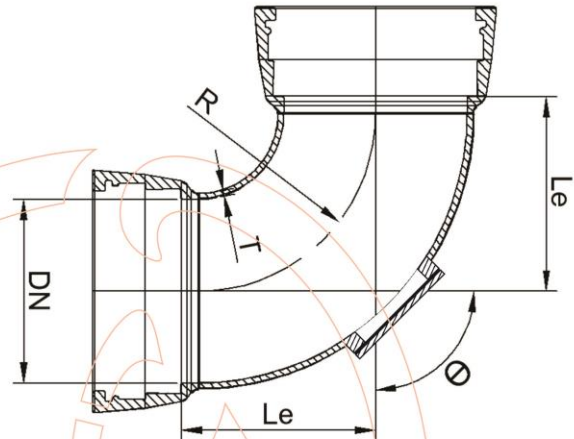

#### 90° Bend - Test Report 90° 邊證書

#### Leaktightness

Size	DN	Le	R	T	θ
mm	mm	mm	mm	mm	mm
80	80	100	80	7.0	90
100	100	120	100	7.2	90
150	150	170	150	7.8	90
200	200	220	200	8.4	90
250	250	270	245	9.0	90
300	300	320	295	9.6	90
* 350	350	370	330	10.2	90
* 400	400	420	380	10.8	90
* 450	450	475	435	11.4	90
* 500	500	520	475	12.0	90
* 600	600	620	570	13.2	90
* 700	700	720	670	14.4	90

**CASTCO** 佳力高試驗中心有限公司  
CASTCO TESTING CENTRE LIMITED

**Test Report**  
Work Leaktightness Test of Ductile Iron Pipes, fittings, accessories and their joints for water pipelines  
[In accordance to EN598: 2007 + A1: 2009 Clause 4.7]

Date of issue: 30 November 2017  
Page 1 of 1 page  
Castco LRN: DP0170529-219 HYD

**Details as supplied by customer:-**  
Customer: TPY Limited  
Address: G/F, No. 120, Tung Tau Tsuen, Shek Pat Heung, Yuen Long, N.T.  
Contract no.: --  
Job title: --  
Customer's ref. no.: --

Description of fitting: --  
Nominal size (DN): 100  
Brand name: TPY  
Pressure testing type: Fitting (All Socket 90 Degree Bend)  
Length: --  
Manufacturer: TPY Limited

Delivery date: --  
Origin: China

**Laboratory Test Result**  
Date of sample received: 29 May 2017  
Date of test: 06 June 2017

Specimen no.	DP0170529-219	
Testing temperature	22.0 °C	
Pressure amplitude maintained	25 bar	
Actual testing time	Time start	0 sec.
	Time end	15 sec.
	Time interval	15 sec.
Any leakage during the test	No.	
Compliance	C	

Notes: Test sample shall withstand the internal pressure without any leakage to EN598: 1995.  
Legends: C - Comply with EN598: 2007 + A1: 2009.  
\* - Do not comply with EN598: 2007 + A1: 2009.  
- Only apply to the specimen tested.  
- The sample comply with the requirement of BS EN 598: 2007 + A1: 2009 Clause 4.7.

Certified by:   
WONG KA MAN  
Senior Manager

End of Report

33, On Kai Street, Fanling, Hong Kong. Tel: 2597 8333  
29A, On Chuan Street, Fanling, Hong Kong. Fax: 2597 8399  
E-mail: info@castco.com.hk Website: www.castco.com.hk

\* and all items with access door made to order.

\* All rights reserved. It is unlawful to copy or extract the whole or the materials from this catalog without the written consent of our company.



祥興鑄鐵有限公司  
CHEUNG HING FOUNDRY (HK) LIMITED



# BS EN 598 Ductile Iron All Socket Fitting With Flexible Joint. (For Sewerage)

## BS EN 598

### 全疏杰柔性膠圈接頭球墨鑄鐵排污配件

## 90° Bend - Test Report 90°邊證書

### Brinell Hardness

### Dimension



**CASTCO** 佳力高試驗中心有限公司  
CASTCO TESTING CENTRE LIMITED

**Test Report**  
Brinell Hardness Test of Ductile Iron Pipes, Fittings and Accessories for Sewerage Application  
(BS EN 598 : 2007 + A1 : 2009 Clause 4.3.2)

Date of issue: 30 November 2017  
Page 1 of 1 page(s)  
Castco LRN: DP0170529-219

**Details as supplied by customer:**  
Customer: TPV Limited  
Address: GF, No. 120, Tung Tau Tsuen, Shap Pat Heung, Yuen Long, N.T.  
Job title: --  
Sample description: --  
Sample I.D.: --  
Nominal Size (DN): 100  
Class: --  
Origin: China

Type: Fitting (All Socket 90 Degree Bend)  
Manufacturer: TPV Limited  
Brand:

Brinell hardness testing machine  
Machine type: 布氏硬式計HB-3000B Series No.: 0125 (BH401)  
Cirt. No.: G1.0170518-12 I.D. No.: NDT-HB-01  
Callipers  
I.D. No.: NDF-HB-007

Labouratory test results:  
Date of received: 29 May 2017  
Date of test: 11 November 2017  
Test specimen thickness: 5.17 mm  
Test temperature: 26 °C

**Sketch of test locations**

Indentation no.	Indentation diameter (2 directions) (mm)	Indentation means (mm)	Corresponding hardness value (HB)	Result
1	4.65 4.67	4.66	166	C
2	4.65 4.68	4.67	165	C
3	4.66 4.67	4.67	165	C

**CASTCO** 佳力高試驗中心有限公司  
CASTCO TESTING CENTRE LIMITED

**Test Report**  
Method for Determination of Dimensions of Ductile Iron Pipes, Fittings, Accessories and Their Joints for Sewerage Applications  
(BS EN 598 : 2007 + A1 : 2009 Clause 4.2 & Clause 4.3)

Date of issue: 30 November 2017  
Page 1 of 2 page(s)  
Castco LRN: DP0170529-219 DIM

**Details as supplied by customer:**  
Customer: TPV Limited  
Address: GF, No. 120, Tung Tau Tsuen, Shap Pat Heung, Yuen Long, N.T.  
Contract no.: --  
Job title: --  
Description of: --  
Nominal bore: 100 mm  
Length: --  
Brand name:

Type: Fitting (All Socket 90 Degree Bend)  
Manufacturer: TPV Limited  
Origin: China

Labouratory Test Result  
Date sample received: 29 May 2017  
Date of test: 02 June 2017  
Specimen no.: DP0170529-219

Nominal size DN: 100	Test result	BS EN requirement	Customer requirement
External diameter (e) (mm)			
Orality spigot of external diameter (mm)			
Thickness (T) (mm)	6.29	7.2 (-2.4)	7.2
Internal diameter (mm)			
Length (Le1) (mm)	110	120 (+18)	120
Length (Le2) (mm)	110	120 (+18)	120
Length (Le) (mm)			
Measured thickness of cement mortar lining (mm)	6.33	4 (-1.5)	--

Remarks: 1. Test results relate only to the specimen tested.  
2. Test results of the sample comply with the requirement of BS EN598:2007+ A1:2009 Clause 4.2 & Clause 4.3.

Checked by:   
SIT KWAN NING  
Labouratory Supervisor

Certified by:   
WONG KA MAN  
Senior Manager

### Surface Condition

**CASTCO** 佳力高試驗中心有限公司  
CASTCO TESTING CENTRE LIMITED

**Test Report**  
Surface Condition Test for Ductile Iron Pipes, Fittings, Accessories and Their Joints for Sewerage Application  
(BS EN 598 : 2007+A1 : 2009 clause 4.1.2)

Date of issue: 30 November 2017  
Page 1 of 1 page(s)  
Castco LRN: DP0170529-219 SC

**Details as supplied by customer:**  
Customer: TPV Limited  
Address: GF, No. 120, Tung Tau Tsuen, Shap Pat Heung, Yuen Long, N.T.  
Job title: --  
Sample Description: --  
Sample I.D.: --  
Nominal size (DN): 100  
Manufacturer: TPV Limited  
Brand:

Type: Fitting (All Socket 90 Degree Bend)  
Nominal length: --  
Origin: China

Labouratory test results:  
Date sample received: 29 May 2017  
Date of test: 02 June 2017

The external surface condition of test sample is free from defect and surface imperfections.

Remark: 1. Test result relate only to the specimens tested.  
2. Test results complies with Clause 4.1.2 of BS EN 598 : 2007 + A1 : 2009.

Checked by:   
SIT KWAN NING  
Labouratory Supervisor

Certified by:   
WONG KA MAN  
Senior Manager

### Tensile

**CASTCO** 佳力高試驗中心有限公司  
CASTCO TESTING CENTRE LIMITED

**Test Report**  
Tensile Test of Ductile Cast Iron  
(BS EN 598 : 2007 + A1 : 2009 Clause 4.3.1)

Date of issue: 16 January 2018  
Page 1 of 1 page  
Castco LRN: DP0170529-219 TEN

**Details as supplied by customer:**  
Customer: TPV Limited  
Job title: --  
Sample Description: DN100 All Socket 90 Degree Bend  
Grade: --  
Manufacturer: TPV Limited  
Acceptance standard: BS EN598 : 2007 + A1 : 2009 Clause 4.3.1  
Brand:

Origin: China

Labouratory test results:  
Date received: 29 May 2017  
Date tested: 11 November 2017

Specimen Mark	Material designation	Gauge dia. (mm)	Cross-sect. area, (mm <sup>2</sup> )	Original gauge length, (mm)	Final gauge length, mm	0.2% Proof stress		Tensile Load		Elongation %	Compliance
						(kN)	(MPa)	(kN)	(MPa)		
DP0170529-219		5.03	19.0	40	45			9.1	458	12.5	C

Remarks: 1. Legends: C - comply with acceptance standard, F - fail to comply with acceptance standard.  
2. Test results relate to the specimen tested only.  
3. Test results comply with requirement of BS EN 598 : 2007 + A1 : 2009 Clause 4.3.1.  
4. This page no. 1A of test report superseded page no. 1 of the previous test report of Castco LRN : DP0170529-219 TEN issued on 30 November 2017.

Checked by:   
SIT KWAN NING  
Labouratory Supervisor

Certified by:   
WONG KA MAN  
Senior Manager

\* All rights reserved. It is unlawful to copy or extract the whole or the materials from this catalog without the written consent of our company.



祥興鑄鐵有限公司  
CHEUNG HING FOUNDRY (HK) LIMITED



# BS EN 598 Ductile Iron All Socket Fitting With Flexible Joint. (For Sewerage)

## BS EN 598

### 全疏杰柔性膠圈接頭球墨鑄鐵排污配件

#### 45° Bend

#### 45° 邊

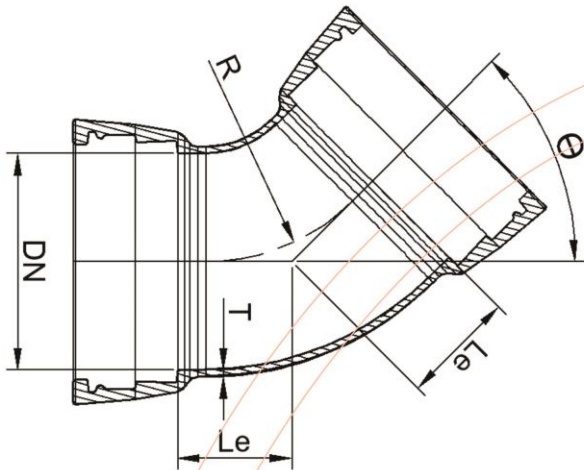

#### 45° Bend with Access door

#### 45° 正口邊

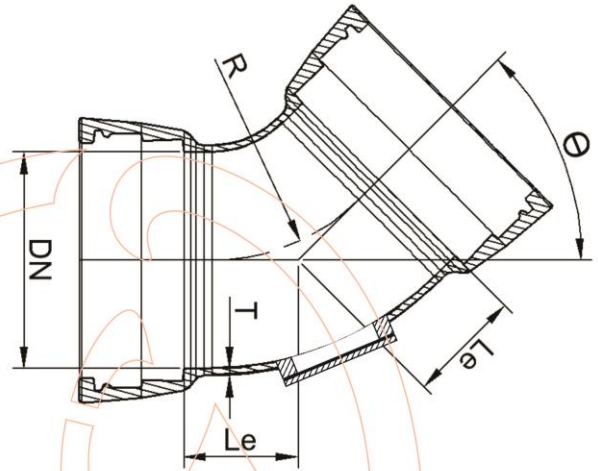

#### 45° Bend - Test Report 45° 邊證書

#### Leaktightness

Size	DN	Le	R	T	θ
mm	mm	mm	mm	mm	mm
80	80	55	80	7.0	45
100	100	65	100	7.2	45
150	150	85	150	7.8	45
200	200	110	200	8.4	45
250	250	130	245	9.0	45
300	300	150	295	9.6	45
* 350	350	175	330	10.2	45
* 400	400	195	380	10.8	45
* 450	450	220	435	11.4	45
* 500	500	240	475	12.0	45
* 600	600	285	570	13.2	45
* 700	700	330	660	14.4	45

**CASTCO** 佳力高試驗中心有限公司  
CASTCO TESTING CENTRE LIMITED

**Test Report**  
Work Leaktightness Test of Ductile Iron Pipes, fittings, accessories and their joints  
for water pipelines.  
[In accordance to JIS598: 2007 + A1 : 2009 Clause 4.7]

Date of issue : December 2017  
Page 1 of 1 page  
Details as supplied by customer:  
Customer: TPY Limited  
Address: G/F, No. 120, Tung Tau Tsuen, Shap Pat Heung, Yuen Long, N.T.  
Contract no.: -- Job title: --  
Customer's ref. no.: --

Castco LRN: DP0170529-225 HYD

Description of fitting: --  
Nominal size (DN): 100  
Byoid name: Length: --  
Pressure testing type: Fitting (All Socket 45 Degree Bend) Manufacturer: TPY Limited

Delivery date: -- Origin: China

**Laboratory Test Result**

Date of sample received: 29 May 2017 Date of test: 06 June 2017

Specimen no.	DP0170529-225	
Testing temperature	22.0 °C	
Pressure amplitude maintained	25 bar	
Actual testing time	Time start	0 sec.
	Time end	15 sec.
	Time interval	15 sec.
Any leakage during the test	No	
Compliance	C	

Notes: Test sample shall withstand the internal pressure without any leakage to EN598 : 1995.  
Legend: C - Comply with EN598 : 2007 + A1 : 2009.  
Compliance only to the specimen tested.  
The sample comply with the requirement of BS EN 598 : 2007 + A1 : 2009 Clause 4.7.

Certified by:   
WONG KA MAN  
Sealer Manager

End of Report

33, On Kai Street, Fanling, Hong Kong Tel: 2597 8333  
29A, On Chuen Street, Fanling, Hong Kong Fax: 2597 8389  
E-mail: info@castco.com.hk Website: www.castco.com.hk

\* and all items with access door made to order.

\* All rights reserved. It is unlawful to copy or extract the whole or the materials from this catalog without the written consent of our company.



祥興鑄鐵有限公司  
CHEUNG HING FOUNDRY (HK) LIMITED



# BS EN 598 Ductile Iron All Socket Fitting With Flexible Joint. (For Sewerage)

## BS EN 598

### 全疏杰柔性膠圈接頭球墨鑄鐵排污配件

## 45° Bend - Test Report 45°邊證書

### Brinell Hardness

### Dimension



**CASTCO** 佳力高試驗中心有限公司  
CASTCO TESTING CENTRE LIMITED

**Test Report**  
Brinell Hardness Test of Ductile Iron Pipes, Fittings and Accessories for Sewerage Application  
(BS EN 598 : 2007 + A1 : 2009 Clause 4.3.2)

Date of issue: 1 December 2017  
Page 1 of 1 page(s)  
Castco LRN: DP0170529-225

**Details as supplied by customer:-**  
Customer: TPY Limited  
Address: GF, No. 120, Tung Tau Tsuen, Shap Pat Heung, Yuen Long, N.T.  
Job title: --  
Sample description: --  
Sample I.D.: --  
Nominal size (DN): 100  
Class: --  
Origin: China

Customer's Ref. No.: --  
Contract No.: --  
Type: Fitting (All Socket 45 Degree Bend)  
Manufacturer: TPY Limited  
Brand:

Brinell hardness testing machine: Machine type: 布氏硬度計HB-3000B Series No.: 0125 (BH01)  
Cert. No.: CL0170518-12 I.D. No.: NDT-HB-01  
Calipers: I.D. No.: NDT-HB-007

**Laboratory test results:-**  
Date of received: 29 May 2017 Date of test: 11 November 2017  
Test specimen thickness: 5.69 mm Test temperature: 26 °C

**Sketch of test locations**

Indentation no.	Indentation diameter (2 directions) (mm)	Indentation means (mm)	Corresponding hardness value (HB)	Results
1	4.65	4.66	166	C
2	4.62	4.68	167	C
3	4.64	4.63	168	C

**CASTCO** 佳力高試驗中心有限公司  
CASTCO TESTING CENTRE LIMITED

**Test Report**  
Method for Determination of Dimensions of Ductile Iron Pipes, Fittings, Accessories and Their Joints for Sewage Applications  
(BS EN 598 : 2007 + A1 : 2009 Clause 4.2 & Clause 4.3.3)

Date of issue: 1 December 2017  
Page 1 of 2 page(s)  
Castco LRN: DP0170529-225 DIM

**Details as supplied by customer:-**  
Customer: TPY Limited  
Address: GF, No. 120, Tung Tau Tsuen, Shap Pat Heung, Yuen Long, N.T.  
Contract no.: --  
Job title: --  
Description of: --  
Nominal bore: 100 mm  
Brand name:   
Delivery date: --  
Origin: China

Customer's ref. no.: --  
Type: Fitting (All Socket 45 Degree Bend)  
Manufacturer: TPY Limited

**Laboratory Test Result**  
Date sample received: 29 May 2017 Date of test: 02 June 2017  
Specimen no. DP0170529-225

Nominal size DN: 100	Test result	BS EN requirement	Customer requirement
External diameter (e)			
Orality (spigot of external diameter)			
Thickness (T)	6.32	7.2 (-2.4)	7.2
Internal diameter			
Length (Le1)	60	65 (±13)	65
Length (Le2)	60	65 (±13)	65
Length (Le)			
Measured thickness of cement mortar lining	4.73	4 (-1.5)	--

Remarks: 1. Test results relate only to the specimen tested.  
2. Test results of the sample comply with the requirement of BS EN 598: 2007 + A1: 2009 Clause 4.2 & Clause 4.3.3.

Checked by:   
SIT KWAN NING  
From the PRC Construction, Laboratory Supervisor  
WONG KA MAN  
Senior Manager

Certified by:   
WONG KA MAN  
Senior Manager  
香港特爾安街33號 33, On Kai Street, Fanling, Hong Kong. Tel: 2597 8333  
香港特爾安街29A號 29A, On Chuen Street, Fanling, Hong Kong. Fax: 2597 8399  
E-mail: info@castco.com.hk Website: www.castco.com.hk

### Surface Condition

**CASTCO** 佳力高試驗中心有限公司  
CASTCO TESTING CENTRE LIMITED

**Test Report**  
Surface Condition Test for Ductile Iron Pipes, Fittings, Accessories and Their Joints for Sewerage Application  
(BS EN 598 : 2007 + A1 : 2009 clause 4.1.2)

Date of issue: 1 December 2017  
Page 1 of 1 page(s)  
Castco LRN: DP0170529-225 SC

**Details as supplied by customer:-**  
Customer: TPY Limited  
Address: GF, No. 120, Tung Tau Tsuen, Shap Pat Heung, Yuen Long, N.T.  
Job title: --  
Sample Description: --  
Sample I.D.: --  
Nominal size (DN): 100  
Manufacturer: TPY Limited

Customer's Ref. No.: --  
Contract No.: --  
Type: Fitting (All Socket 45 Degree Bend)  
Brand:   
Origin: China

**Laboratory test results:-**  
Date sample received: 29 May 2017 Date of test: 02 June 2017

The external surface condition of test sample is free from defect and surface imperfections.

Remark: 1. Test result relate only to the specimens tested.  
2. Test results complies with Clause 4.1.2 of BS EN 598 : 2007 + A1 : 2009.

Checked by:   
SIT KWAN NING  
Laboratory Supervisor  
End of Report  
WONG KA MAN  
Senior Manager

香港特爾安街33號 33, On Kai Street, Fanling, Hong Kong. Tel: 2597 8333  
香港特爾安街29A號 29A, On Chuen Street, Fanling, Hong Kong. Fax: 2597 8399  
E-mail: info@castco.com.hk Website: www.castco.com.hk

### Tensile

**CASTCO** 佳力高試驗中心有限公司  
CASTCO TESTING CENTRE LIMITED

**Test Report**  
Tensile Test of Ductile Cast Iron  
(BS EN 598 : 2007 + A1 : 2009 Clause 4.3.1)

Date of issue: 16 January 2018  
Page 1A of 1 page  
Castco LRN: DP0170529-225 TEN

**Details as supplied by customer:-**  
Customer: TPY Limited  
Job title: --  
Sample Description: DN100 All Socket 45 Degree Bend  
Grade: --  
Manufacturer: TPY Limited  
Acceptance standard: BS EN 598 : 2007 + A1 : 2009 Clause 4.3.1  
Brand:   
Origin: China

**Laboratory test results:-**  
Date received: 29 May 2017 Date tested: 11 November 2017

Specimen Mark	Material designation		Gauge dia. (mm)	Cross-sect. area, (mm <sup>2</sup> )	Original gauge length, (mm)	Final gauge length, mm	0.2% Proof stress (kN) (MPa)	Tensile Load (kN) (MPa)	Elongation %	Compliance	
	Symbol	Number									
DP0170529-225	--	--	5.02	19.8	40	44		8.5	430	10	C

Remarks: 1. Legends: C - comply with acceptance standard, F - fail to comply with acceptance standard.  
2. Test results relate to the specimen tested only.  
3. Test results comply with requirement of BS EN 598 : 2007 + A1 : 2009 Clause 4.3.1.  
4. This page no.1A of test report superseded page no.1 of the previous test report of Castco LRN : DP0170529-225 TEN issued on 1 December 2017.

Checked by:   
SIT KWAN NING  
Laboratory Supervisor  
End of Report  
WONG KA MAN  
Senior Manager

\* All rights reserved. It is unlawful to copy or extract the whole or the materials from this catalog without the written consent of our company.



祥興鑄鐵有限公司  
CHEUNG HING FOUNDRY (HK) LIMITED



# BS EN 598 Ductile Iron All Socket Fitting With Flexible Joint. (For Sewerage)

## BS EN 598

### 全疏杰柔性膠圈接頭球墨鑄鐵排污配件

#### 90° Long Radius Bend

#### 90°大彎邊

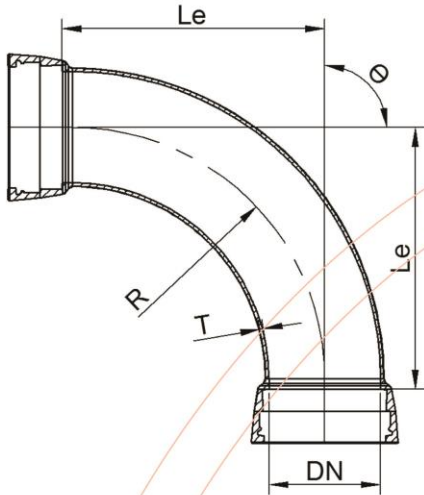

#### 90° Long Radius Bend with Access door

#### 90°正口大彎邊

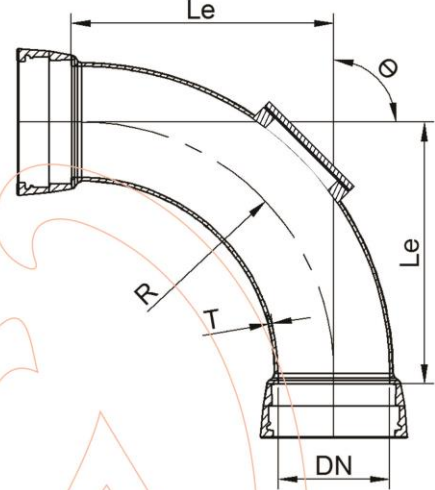

#### 90° Long Radius Bend - Test Report

#### 90°大彎邊證書

#### Leaktightness

Size	DN	Le	R	T	θ
mm	mm	mm	mm	mm	mm
80	80	370	350	7.0	90
100	100	395	375	7.2	90
150	150	435	420	7.8	90
200	200	490	470	8.4	90
250	250	545	520	9.0	90
300	300	590	565	9.6	90
* 350	350	645	620	10.2	90
* 400	400	690	665	10.8	90
* 450	450	745	720	11.4	90
* 500	500	790	765	12.0	90
* 600	600	890	865	13.2	90
* 700	700	990	965	14.4	90

**CASTCO** 佳力高試驗中心有限公司  
CASTCO TESTING CENTRE LIMITED

**Test Report**  
Work Leaktightness Test of Ductile Iron Pipes, fittings, accessories and their joints  
for water pipelines  
[In accordance to EN598: 2007 + A1: 2009 Clause 4.7]

Date of issue: December 2017  
Page 1 of 1 page  
Details as supplied by customer: Castco LRN: DP0170529-231 HYD  
Customer: TPY Limited  
Address: G/E, No. 120, Tung Tau Tsuen, Shap Pat Heung, Yuen Long, N.T.  
Contract no.: -- Job title: -- Customer's ref. no.: --

Description of fitting: --  
Nominal size (DN): 100 Length: --  
Brand name: Castco Manufacturer: TPY Limited  
Pressure testing type: (Fitting) All Socket 90 Degree Long Radius Bend  
Delivery date: -- Origin: China

**Laboratory Test Result**  
Date of sample received: 29 May 2017 Date of test: 06 June 2017

Specimen no.	DP0170529-231	
Testing temperature	22.0 °C	
Pressure amplitude maintained	25 bar	
Actual testing time	Time start	0 sec.
	Time end	15 sec.
	Time interval	15 sec.
Any leakage during the test	No.	
Compliance	C	

Notes: Test sample shall withstand the internal pressure without any leakage to EN598: 1995.  
Legends: C - Comply with EN598: 2007 + A1: 2009.  
\* - Do not comply with EN598: 2007 + A1: 2009.  
- - - Only apply to the specimen tested.  
- - - The sample comply with the requirement of BS EN 598: 2007 + A1: 2009 Clause 4.7.

Certified by:   
WONG KA MAN  
Sales Manager

End of Report

33號 33, On Kai Street, Fanling, Hong Kong. Tel: 2597 8333  
29A, On Chuen Street, Fanling, Hong Kong. Fax: 2597 8399  
E-mail: info@castco.com.hk Website: www.castco.com.hk

\* and all items with access door made to order.

\* All rights reserved. It is unlawful to copy or extract the whole or the materials from this catalog without the written consent of our company.



祥興鑄鐵有限公司  
CHEUNG HING FOUNDRY (HK) LIMITED



# BS EN 598 Ductile Iron All Socket Fitting With Flexible Joint. (For Sewerage)

## BS EN 598

### 全疏杰柔性膠圈接頭球墨鑄鐵排污配件

## 90° Long Radius Bend - Test Report 90°大彎邊證書

### Brinell Hardness

### Dimension



**CASTCO** 佳力高試驗中心有限公司  
CASTCO TESTING CENTRE LIMITED

**Test Report**  
Brinell Hardness Test of Ductile Iron Pipes, Fittings and Accessories for Sewerage Application  
[BS EN 598 : 2007 + A1 : 2009 Clause 4.3.2]

Date of issue: 1 December 2017  
Page 1 of 1 page(s)  
Castco LRN: DP0170529-231

**Details as supplied by customer:-**  
Customer: TPV Limited  
Address: GF, No. 120, Tung Tau Tsuen, Shap Pat Heung, Yuen Long, N.T.  
Job title: --  
Sample description: --  
Sample I.D.: --  
Nominal size (DN): 100  
Class: --  
Origin: China  
Type: Fitting (All Socket 90 Degree Long Radius Bend)  
Manufacturer: TPV Limited  
Brand:

Brinell hardness testing machine: Machine type: 布氏硬度計HB-3000B Series No.: 0125 (BH01)  
Cert. No.: CL0170518-12 I.D. No.: NDT-HB-01  
Calipers: I.D. No.: NDT-HB-007

**Laboratory test results:-**  
Date of received: 29 May 2017 Date of test: 11 November 2017  
Test specimen thickness: 7.03 mm Test temperature: 26 °C

**Sketch of test locations**

Indentation no.	Indentation diameter (2 directions) (mm)		Indentation means (mm)	Corresponding hardness value (HB)	Results
1	4.61	4.59	4.60	170	C
2	4.59	4.57	4.58	172	C
3	4.54	4.56	4.55	174	C

**CASTCO** 佳力高試驗中心有限公司  
CASTCO TESTING CENTRE LIMITED

**Test Report**  
Method for Determination of Dimensions of Ductile Iron Pipes, Fittings, Accessories and Their Joints for Sewage Applications  
[BS EN 598 : 2007 + A1 : 2009 Clause 4.2 & Clause 4.3.3]

Date of issue: 1 December 2017  
Page 1 of 2 page(s)  
Castco LRN: DP0170529-231 DIM

**Details as supplied by customer:-**  
Customer: TPV Limited  
Address: GF, No. 120, Tung Tau Tsuen, Shap Pat Heung, Yuen Long, N.T.  
Contract no.: --  
Job title: --  
Customer's ref. no.: --  
Description of: --  
Nominal bore: 100 mm  
Length: --  
Brand name:   
Type: Fitting (All Socket 90 Degree Long Radius Bend)  
Delivery date: --  
Manufacturer: TPV Limited  
Origin: China

**Laboratory Test Result**  
Date sample received: 29 May 2017 Date of test: 02 June 2017  
Specimen no. DP0170529-231

Nominal size DN: 100	Test result	BS EN requirement	Customer requirement
External diameter (e) (mm)			
Quality spigot of external diameter (mm)			
Thickness (T) (mm)	6.72	--	7.2
Internal diameter (mm)			
Length (Le1) (mm)	392	--	395
Length (Le2) (mm)	392	--	395
Length (La) (mm)			
Measured thickness of cement mortar lining (mm)	5.6	4 (-1.5)	--

**Remarks:**  
1. Test results relate only to the specimen tested.  
2. Compliance check against BS EN 598: 2007+A1:2009 clause 4.2 was not possible as this fitting could not be found in the standard.

Checked by:   
SIT KWAN NING  
Senior Manager  
WONG KA MAN  
Senior Manager

### Surface Condition

**CASTCO** 佳力高試驗中心有限公司  
CASTCO TESTING CENTRE LIMITED

**Test Report**  
Surface Condition Test for Ductile Iron Pipes, Fittings, Accessories and Their Joints for Sewerage Application  
[BS EN 598 : 2007+A1 : 2009 clause 4.1.2]

Date of issue: 1 December 2017  
Page 1 of 1 page(s)  
Castco LRN: DP0170529-231 SC

**Details as supplied by customer:-**  
Customer: TPV Limited  
Address: GF, No. 120, Tung Tau Tsuen, Shap Pat Heung, Yuen Long, N.T.  
Job title: --  
Sample Description: --  
Sample I.D.: --  
Nominal size (DN): 100  
Manufacturer: TPV Limited  
Brand:   
Origin: China  
Type: Fitting (All Socket 90 Degree Long Radius Bend)  
Nominal length: --

**Laboratory test results:-**  
Date sample received: 29 May 2017 Date of test: 02 June 2017

The external surface condition of test sample is free from defect and surface imperfections.

**Remark:**  
1. Test result relate only to the specimens tested.  
2. Test results complies with Clause 4.1.2 of BS EN 598 : 2007 + A1 : 2009.

Checked by:   
SIT KWAN NING  
Laboratory Supervisor  
WONG KA MAN  
Senior Manager

### Tensile

**CASTCO** 佳力高試驗中心有限公司  
CASTCO TESTING CENTRE LIMITED

**Test Report**  
Tensile Test of Ductile Cast Iron  
[BS EN 598 : 2007 + A1 : 2009 Clause 4.3.1]

Date of issue: 16 January 2018  
Page 1A of 1 page  
Castco LRN: DP0170529-231 TEN

**Details as supplied by customer:-**  
Customer: TPV Limited  
Job title: --  
Sample Description: DN100 All Socket 90 Degree Long Radius Bend  
Grade: --  
Manufacturer: TPV Limited  
Acceptance standard: BS EN598: 2007 + A1 : 2009 Clause 4.3.1  
Brand:   
Origin: China

**Laboratory test results:-**  
Date received: 29 May 2017 Date tested: 11 November 2017

Specimen Mark	Material designation		Gauge dia. (mm)	Cross-sect. area (mm <sup>2</sup> )	Original gauge length (mm)	Final gauge length (mm)	0.2% Proof stress (kN) (MPa)	Tensile Load		Elongation %	Compliance
	Symbol	Number						(kN)	(MPa)		
DP0170529-231	--	--	5.05	20.0	40	45		8.5	424	12.5	C

**Remarks:**  
1. Legends: C = comply with acceptance standard, F = fail to comply with acceptance standard.  
2. Test results relate to the specimen tested only.  
3. Test results comply with requirement of BS EN 598 : 2007 + A1 : 2009 Clause 4.3.1.  
4. This page no. 1A of test report superseded page no. 1 of the previous test report of Castco LRN : DP0170529-231 TEN issued on 1 December 2017.

Checked by:   
SIT KWAN NING  
Laboratory Supervisor  
WONG KA MAN  
Senior Manager

18

\* All rights reserved. It is unlawful to copy or extract the whole or the materials from this catalog without the written consent of our company.



祥興鑄鐵有限公司  
CHEUNG HING FOUNDRY (HK) LIMITED



# BS EN 598 Ductile Iron All Socket Fitting With Flexible Joint. (For Sewerage)

## BS EN 598

### 全疏杰柔性膠圈接頭球墨鑄鐵排污配件

#### 90° Bend

#### 90° 邊

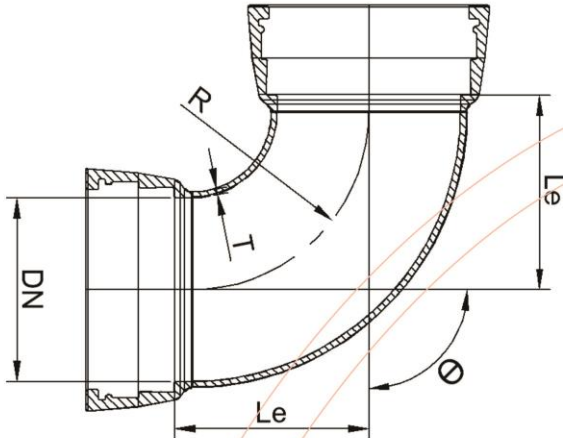

#### 90° Bend with Access door

#### 90° 正口邊

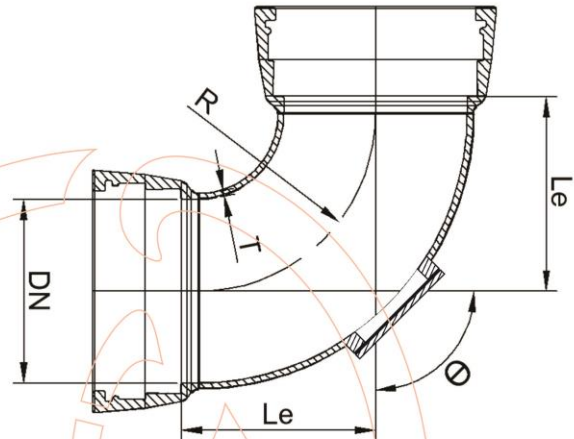

#### 90° Bend - Test Report 90° 邊證書

#### Leaktightness

Size	DN	Le	R	T	θ
mm	mm	mm	mm	mm	mm
80	80	100	80	7.0	90
100	100	120	100	7.2	90
150	150	170	150	7.8	90
200	200	220	200	8.4	90
250	250	270	245	9.0	90
300	300	320	295	9.6	90
* 350	350	370	330	10.2	90
* 400	400	420	380	10.8	90
* 450	450	475	435	11.4	90
* 500	500	520	475	12.0	90
* 600	600	620	570	13.2	90
* 700	700	720	670	14.4	90

**CASTCO** 佳力高試驗中心有限公司  
CASTCO TESTING CENTRE LIMITED

**Test Report**  
Work Leaktightness Test of Ductile Iron Pipes, fittings, accessories and their joints for water pipelines  
[In accordance to EN598: 2007 + A1: 2009 Clause 4.7]

Date of issue: 30 November 2017  
Page 1 of 1 page  
Castco LRN: DP0170529-219 HYD

**Details as supplied by customer:-**  
Customer: TPY Limited  
Address: G/F, No. 120, Tung Tau Tsuen, Shap Pat Heung, Yuan Long, N.T.  
Contract no.: --  
Job title: --  
Customer's ref. no.: --

Description of fitting: --  
Nominal size (DN): 100  
Brand name: Length: --  
Pressure testing type: Fitting (All Socket 90 Degree Bend) Manufacturer: TPY Limited

Delivery date: -- Origin: China

**Laboratory Test Result**  
Date of sample received: 29 May 2017 Date of test: 06 June 2017

Specimen no.	DP0170529-219	
Testing temperature	22.0 °C	
Pressure amplitude maintained	25 bar	
Actual testing time	Time start	0 sec.
	Time end	15 sec.
	Time interval	15 sec.
Any leakage during the test	No.	
Compliance	C	

Notes: Test sample shall withstand the internal pressure without any leakage to EN598: 1995.  
Legends: C - Comply with EN598: 2007 + A1: 2009.  
-- Do not comply with EN598: 2007 + A1: 2009.  
\* Only apply to the specimen tested.  
\* The sample comply with the requirement of BS EN 598: 2007 + A1: 2009 Clause 4.7.

Certified by:   
WONG KA MAN  
Senior Manager

End of Report

33, On Kai Street, Fanling, Hong Kong. Tel: 2597 8333  
29A, On Chuan Street, Fanling, Hong Kong. Fax: 2597 8399  
E-mail: info@castco.com.hk Website: www.castco.com.hk

\* and all items with access door made to order.

\* All rights reserved. It is unlawful to copy or extract the whole or the materials from this catalog without the written consent of our company.



祥興鑄鐵有限公司  
CHEUNG HING FOUNDRY (HK) LIMITED





# BS EN 598 Ductile Iron All Socket Fitting With Flexible Joint. (For Sewerage)

## BS EN 598

### 全疏杰柔性膠圈接頭球墨鑄鐵排污配件

## 90° Bend - Test Report 90°邊證書

### Brinell Hardness

### Dimension



**CASTCO** 佳力高試驗中心有限公司  
CASTCO TESTING CENTRE LIMITED

**Test Report**  
Brinell Hardness Test of Ductile Iron Pipes, Fittings and Accessories for Sewerage Application  
(BS EN 598 : 2007 + A1 : 2009 Clause 4.3.2)

Date of issue: 30 November 2017  
Page 1 of 1 page(s)  
Castco LRN: DP0170529-219

**Details as supplied by customer:**  
Customer: TPV Limited  
Address: GF, No. 120, Tung Tau Tsuen, Shap Pat Heung, Yuen Long, N.T.  
Job title: --  
Sample description: --  
Sample I.D.: --  
Nominal Size (DN): 100  
Class: --  
Origin: China

Type: Fitting (All Socket 90 Degree Bend)  
Manufacturer: TPV Limited  
Brand:

Brinell hardness testing machine  
Machine type: 布氏硬式計HB-3000B Series No.: 0125 (BH401)  
Cirt. No.: G1.0170518-12 I.D. No.: NDT-HB-01  
Callipers I.D. No.: NDF-HB-007

Labouratory test results:  
Date of received: 29 May 2017 Date of test: 11 November 2017  
Test specimen thickness: 5.17 mm Test temperature: 26 °C

**Sketch of test locations**

Indentation no.	Indentation diameter (2 directions) (mm)		Indentation means (mm)	Corresponding hardness value (HB)	Result
1	4.65	4.67	4.66	166	C
2	4.65	4.68	4.67	165	C
3	4.66	4.67	4.67	165	C

**CASTCO** 佳力高試驗中心有限公司  
CASTCO TESTING CENTRE LIMITED

**Test Report**  
Method for Determination of Dimensions of Ductile Iron Pipes, Fittings, Accessories and Their Joints for Sewerage Applications  
(BS EN 598 : 2007 + A1 : 2009 Clause 4.2 & Clause 4.3)

Date of issue: 30 November 2017  
Page 1 of 2 page(s)  
Castco LRN: DP0170529-219 DIM

**Details as supplied by customer:**  
Customer: TPV Limited  
Address: GF, No. 120, Tung Tau Tsuen, Shap Pat Heung, Yuen Long, N.T.  
Contract no.: -- Job title: --  
Description of: --  
Nominal bore: 100 mm Length: --  
Brand name: Type: Fitting (All Socket 90 Degree Bend)  
Delivery date: -- Manufacturer: TPV Limited  
Origin: China

**Labouratory Test Result**  
Date sample received: 29 May 2017 Date of test: 02 June 2017  
Specimen no.: DP0170529-219

Nominal size DN: 100	Test result	BS EN requirement	Customer requirement
External diameter (e) (mm)			
Orality spigot of external diameter (mm)			
Thickness (T) (mm)	6.29	7.2 (-2.4)	7.2
Internal diameter (mm)			
Length (Le1) (mm)	110	120 (+18)	120
Length (Le2) (mm)	110	120 (+18)	120
Length (Le4) (mm)			
Measured thickness of cement mortar lining (mm)	6.33	4 (-1.5)	--

Remarks: 1. Test results relate only to the specimen tested.  
2. Test results of the sample comply with the requirement of BS EN598:2007+ A1:2009 Clause 4.2 & Clause 4.3.

Checked by: Certified by:

WONG KA MAN  
Senior Manager  
Kong. Tel: 2597 8333  
Kong. Fax: 2597 8399  
com.hk

### Surface Condition

**CASTCO** 佳力高試驗中心有限公司  
CASTCO TESTING CENTRE LIMITED

**Test Report**  
Surface Condition Test for Ductile Iron Pipes, Fittings, Accessories and Their Joints for Sewerage Application  
(BS EN 598 : 2007+A1 : 2009 clause 4.1.2)

Date of issue: 30 November 2017  
Page 1 of 1 page(s)  
Castco LRN: DP0170529-219 SC

**Details as supplied by customer:**  
Customer: TPV Limited  
Address: GF, No. 120, Tung Tau Tsuen, Shap Pat Heung, Yuen Long, N.T.  
Job title: --  
Sample Description: --  
Sample I.D.: --  
Nominal size (DN): 100  
Manufacturer: TPV Limited  
Brand:

Type: Fitting (All Socket 90 Degree Bend)  
Nominal length: --  
Origin: China

Labouratory test results:  
Date sample received: 29 May 2017 Date of test: 02 June 2017  
The external surface condition of test sample is free from defect and surface imperfections.

Remark: 1. Test result relate only to the specimens tested.  
2. Test results complies with Clause 4.1.2 of BS EN 598 : 2007 + A1 : 2009.

Checked by: Certified by:

SIT KWAN NING  
Laboratory Supervisor  
WONG KA MAN  
Senior Manager  
Form No.: PPE-SC/2009/1 of 10/2009/1 (1/10)

香港特維安街33號 33, On Kwi Street, Fanning, Hong Kong. Tel: 2597 8333  
香港特維安街29A號 29A, On Chuen Street, Fanning, Hong Kong. Fax: 2597 8399  
E-mail: info@castco.com.hk Website: www.castco.com.hk

### Tensile

**CASTCO** 佳力高試驗中心有限公司  
CASTCO TESTING CENTRE LIMITED

**Test Report**  
Tensile Test of Ductile Cast Iron  
(BS EN 598 : 2007 + A1 : 2009 Clause 4.3.1)

Date of issue: 16 January 2018  
Page 1 of 1 page  
Castco LRN: DP0170529-219 TEN

**Details as supplied by customer:**  
Customer: TPV Limited  
Job title: --  
Sample Description: DN100 All Socket 90 Degree Bend  
Grade: --  
Manufacturer: TPV Limited  
Acceptance standard: BS EN598 : 2007 + A1 : 2009 Clause 4.3.1  
Brand:

Date received: 29 May 2017 Date tested: 11 November 2017

Specimen Mark	Material designation		Gauge dia. (mm)	Cross-sect. area, (mm <sup>2</sup> )	Original gauge length, (mm)	Final gauge length, mm	0.2% Proof stress		Tensile Load		Elongation %	Compliance
	Symbol	Number					(kN)	(MPa)	(kN)	(MPa)		
DP0170529-219			5.03	19.0	40	45			9.1	458	12.5	C

Remarks: 1. Legends: C - comply with acceptance standard, F - fail to comply with acceptance standard.  
2. Test results relate to the specimen tested only.  
3. Test results comply with requirement of BS EN 598 : 2007 + A1 : 2009 Clause 4.3.1.  
4. This page no. 1A of test report superseded page no. 1 of the previous test report of Castco LRN : DP0170529-219 TEN issued on 30 November 2017.

Checked by: Certified by:

SIT KWAN NING  
Laboratory Supervisor  
WONG KA MAN  
Senior Manager  
Form No.: STL-DUCTILE/TEST/2009/1 of 10/2009/1 (1/10)

\* All rights reserved. It is unlawful to copy or extract the whole or the materials from this catalog without the written consent of our company.



祥興鑄鐵有限公司  
CHEUNG HING FOUNDRY (HK) LIMITED



# BS EN 598 Ductile Iron All Socket Fitting With Flexible Joint. (For Sewerage)

## BS EN 598

### 全疏杰柔性膠圈接頭球墨鑄鐵排污配件

#### 45° Bend

#### 45° 邊

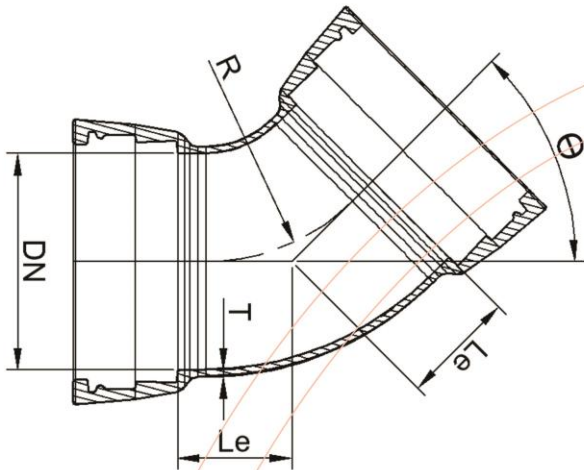

#### 45° Bend with Access door

#### 45° 正口邊

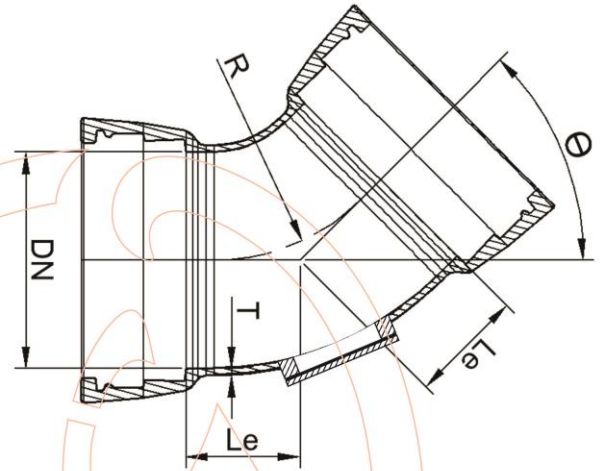

#### 45° Bend - Test Report

#### 45° 邊證書

#### Leaktightness

Size	DN	Le	R	T	θ
mm	mm	mm	mm	mm	mm
80	80	55	80	7.0	45
100	100	65	100	7.2	45
150	150	85	150	7.8	45
200	200	110	200	8.4	45
250	250	130	245	9.0	45
300	300	150	295	9.6	45
* 350	350	175	330	10.2	45
* 400	400	195	380	10.8	45
* 450	450	220	435	11.4	45
* 500	500	240	475	12.0	45
* 600	600	285	570	13.2	45
* 700	700	330	660	14.4	45

**CASTCO** 佳力高試驗中心有限公司  
CASTCO TESTING CENTRE LIMITED

**Test Report**  
Work Leaktightness Test of Ductile Iron Pipes, fittings, accessories and their joints for water pipelines.  
[In accordance to JIS598: 2007 + A1 : 2009 Clause 4.7]

Date of issue : December 2017  
Page 1 of 1 page  
Castco LRN: DP0170529-225 HYD

Details as supplied by customer:  
Customer: TPY Limited  
Address: G/F, No. 120, Tung Tau Tsuen, Shap Pat Heung, Yuen Long, N.T.  
Contract no.: --  
Job title: --  
Customer's ref. no.: --

Description of fitting: --  
Nominal size (DN): 100  
Byoid name: Length: --  
Pressure testing type: Fitting (All Socket 45 Degree Bend) Manufacturer: TPY Limited

Delivery date: -- Origin: China

**Laboratory Test Result**  
Date of sample received: 29 May 2017 Date of test: 06 June 2017

Specimen no.	DP0170529-225	
Testing temperature	22.0 °C	
Pressure amplitude maintained	25 bar	
Actual testing time	Time start	0 sec.
	Time end	15 sec.
	Time interval	15 sec.
Any leakage during the test	No	
Compliance	C	

Notes: Test sample shall withstand the internal pressure without any leakage to EN598 : 1995.  
Legend: C - Comply with EN598 : 2007 + A1 : 2009.  
Compliance only to the specimen tested.  
The sample comply with the requirement of BS EN 598 : 2007 + A1 : 2009 Clause 4.7.

Certified by:   
WONG KA MAN  
Sealer Manager

End of Report

33, On Kai Street, Fanling, Hong Kong Tel: 2597 8333  
29A, On Chuen Street, Fanling, Hong Kong Fax: 2597 8389  
E-mail: info@castco.com.hk Website: www.castco.com.hk

\* and all Items with access door made to order.

\* All rights reserved. It is unlawful to copy or extract the whole or the materials from this catalog without the written consent of our company.



祥興鑄鐵有限公司  
CHEUNG HING FOUNDRY (HK) LIMITED



# BS EN 598 Ductile Iron All Socket Fitting With Flexible Joint. (For Sewerage)

## BS EN 598 全疏杰柔性膠圈接頭球墨鑄鐵排污配件

### 45° Bend - Test Report 45°邊證書

#### Brinell Hardness

#### Dimension



**CASTCO** 佳力高試驗中心有限公司  
CASTCO TESTING CENTRE LIMITED

**Test Report**  
Brinell Hardness Test of Ductile Iron Pipes, Fittings and Accessories for Sewerage Application  
(BS EN 598 : 2007 + A1 : 2009 Clause 4.3.2)

Date of issue: 1 December 2017  
Page 1 of 1 page(s)  
Castco LRN: DP0170529-225

**Details as supplied by customer:-**  
Customer: TPY Limited  
Address: GF, No. 120, Tung Tau Tsuen, Shap Pat Heung, Yuen Long, N.T.  
Job title: --  
Sample description: --  
Sample I.D.: --  
Nominal size (DN): 100  
Class: --  
Origin: China

Type: Fitting (All Socket 45 Degree Bend)  
Manufacturer: TPY Limited  
Brand:

Brinell hardness testing machine  
Machine type: 布氏硬度計HB-3000B Series No.: 0125 (BH01)  
Cert. No.: CL0170518-12 I.D. No.: NDT-HB-01

**Laboratory test results:-**  
Date received: 29 May 2017 Date of test: 11 November 2017  
Test specimen thickness: 5.69 mm Test temperature: 26 °C

**Sketch of test locations**

Indentation no.	Indentation diameter (2 directions) (mm)	Indentation means (mm)	Corresponding hardness value (HB)	Results
1	4.65	4.66	166	C
2	4.62	4.68	167	C
3	4.64	4.63	168	C

**CASTCO** 佳力高試驗中心有限公司  
CASTCO TESTING CENTRE LIMITED

**Test Report**  
Method for Determination of Dimensions of Ductile Iron Pipes, Fittings, Accessories and Their Joints for Sewage Applications  
(BS EN 598 : 2007 + A1 : 2009 Clause 4.2 & Clause 4.3.3)

Date of issue: 1 December 2017  
Page 1 of 2 page(s)  
Castco LRN: DP0170529-225 DIM

**Details as supplied by customer:-**  
Customer: TPY Limited  
Address: GF, No. 120, Tung Tau Tsuen, Shap Pat Heung, Yuen Long, N.T.  
Contract no.: --  
Job title: --  
Description of: --  
Nominal bore: 100 mm  
Length: --  
Brand name:

Type: Fitting (All Socket 45 Degree Bend)  
Manufacturer: TPY Limited  
Delivery date: --  
Origin: China

**Laboratory Test Result**  
Date sample received: 29 May 2017 Date of test: 02 June 2017  
Specimen no. DP0170529-225

Nominal size DN: 100	Test result	BS EN requirement	Customer requirement
External diameter (e)			
Quality spigot of external diameter			
Thickness (T)	6.32	7.2 (-2.4)	7.2
Internal diameter			
Length (Le1)	60	65 (+13)	65
Length (Le2)	60	65 (+13)	65
Length (Le)			
Measured thickness of cement mortar lining	4.73	4 (-1.5)	--

Remarks: 1. Test results relate only to the specimen tested.  
2. Test results of the sample comply with the requirement of BS EN 598: 2007 + A1: 2009 Clause 4.2 & Clause 4.3.3.

Checked by: SIK KWAN NING  
Certified by: WONG KA MAN

#### Surface Condition

**CASTCO** 佳力高試驗中心有限公司  
CASTCO TESTING CENTRE LIMITED

**Test Report**  
Surface Condition Test for Ductile Iron Pipes, Fittings, Accessories and Their Joints for Sewerage Application  
(BS EN 598 : 2007 + A1 : 2009 clause 4.1.2)

Date of issue: 1 December 2017  
Page 1 of 1 page(s)  
Castco LRN: DP0170529-225 SC

**Details as supplied by customer:-**  
Customer: TPY Limited  
Address: GF, No. 120, Tung Tau Tsuen, Shap Pat Heung, Yuen Long, N.T.  
Job title: --  
Sample Description: --  
Sample I.D.: --  
Nominal size (DN): 100  
Manufacturer: TPY Limited  
Brand:

Type: Fitting (All Socket 45 Degree Bend)  
Nominal length: --  
Origin: China

**Laboratory test results:-**  
Date sample received: 29 May 2017 Date of test: 02 June 2017

The external surface condition of test sample is free from defect and surface imperfections.

Remark: 1. Test result relate only to the specimens tested.  
2. Test results complies with Clause 4.1.2 of BS EN 598 : 2007 + A1 : 2009.

Checked by: SIK KWAN NING  
Certified by: WONG KA MAN

#### Tensile

**CASTCO** 佳力高試驗中心有限公司  
CASTCO TESTING CENTRE LIMITED

**Test Report**  
Tensile Test of Ductile Cast Iron  
(BS EN 598 : 2007 + A1 : 2009 Clause 4.3.1)

Date of issue: 16 January 2018  
Page 1A of 1 page  
Castco LRN: DP0170529-225 TEN

**Details as supplied by customer:-**  
Customer: TPY Limited  
Job title: --  
Sample Description: DN100 All Socket 45 Degree Bend  
Grade: --  
Manufacturer: TPY Limited  
Acceptance standard: BS EN 598 : 2007 + A1 : 2009 Clause 4.3.1  
Brand:

Origin: China

**Laboratory test results:-**  
Date received: 29 May 2017 Date tested: 11 November 2017

Specimen Mark	Material designation		Gauge dia. (mm)	Cross-sect. area (mm <sup>2</sup> )	Original gauge length (mm)	Final gauge length (mm)	0.2% Proof stress (kN) (MPa)	Tensile Load (kN) (MPa)	Elongation %	Compliance	
	Symbol	Number									
DP0170529-225	--	--	5.02	19.8	40	44		8.5	430	10	C

Remarks: 1. Legends: C - comply with acceptance standard; F - fail to comply with acceptance standard.  
2. Test results relate to the specimen tested only.  
3. Test results comply with requirement of BS EN 598 : 2007 + A1 : 2009 Clause 4.3.1.  
4. This page no. 1A of test report superseded page no. 1 of the previous test report of Castco LRN : DP0170529-225 TEN issued on 1 December 2017.

Checked by: SIK KWAN NING  
End of Report  
Certified by: WONG KA MAN

\* All rights reserved. It is unlawful to copy or extract the whole or the materials from this catalog without the written consent of our company.



# 祥興鑄鐵有限公司 CHEUNG HING FOUNDRY (HK) LIMITED



# BS EN 598 Ductile Iron All Socket Fitting With Flexible Joint. (For Sewerage)

## BS EN 598

### 全疏杰柔性膠圈接頭球墨鑄鐵排污配件

#### 90° Long Radius Bend

#### 90°大彎邊

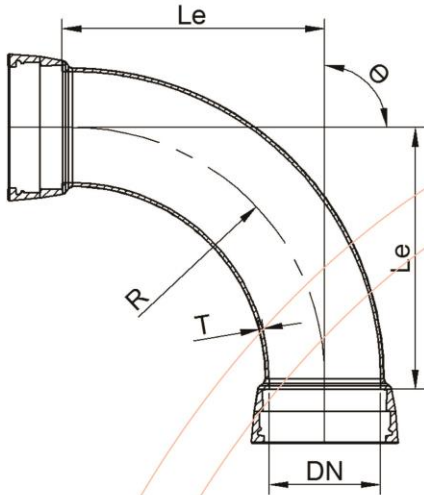

#### 90° Long Radius Bend with Access door

#### 90°正口大彎邊

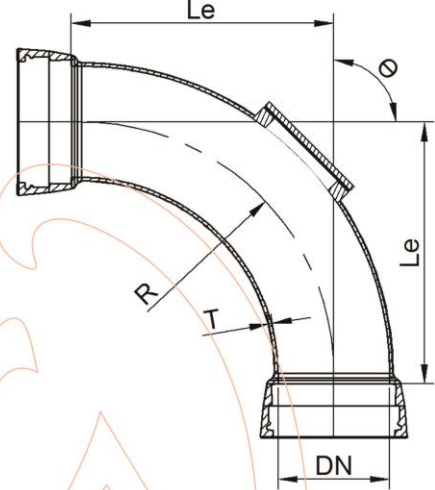

#### 90° Long Radius Bend - Test Report

#### 90°大彎邊證書

#### Leaktightness

Size	DN	Le	R	T	θ
mm	mm	mm	mm	mm	mm
80	80	370	350	7.0	90
100	100	395	375	7.2	90
150	150	435	420	7.8	90
200	200	490	470	8.4	90
250	250	545	520	9.0	90
300	300	590	565	9.6	90
* 350	350	645	620	10.2	90
* 400	400	690	665	10.8	90
* 450	450	745	720	11.4	90
* 500	500	790	765	12.0	90
* 600	600	890	865	13.2	90
* 700	700	990	965	14.4	90

**CASTCO** 佳力高試驗中心有限公司  
CASTCO TESTING CENTRE LIMITED

**Test Report**  
Work Leaktightness Test of Ductile Iron Pipes, fittings, accessories and their joints  
for water pipelines  
[In accordance to EN598 : 2007 + A1 : 2009 Clause 4.7]

Date of issue : December 2017  
Page 1 of 1 page  
Details as supplied by customer:  
Customer: TPY Limited  
Address: G/E, No. 120, Tung Tau Tsuen, Shap Pat Heung, Yuen Long, N.T.  
Contract no.: --  
Job title: --  
Customer's ref. no.: --

Castco LRN: DP0170529-231 HYD

Description of fitting: --  
Nominal size (DN): 100  
Braid name: 450  
Pressure testing type: (Fitting) All Socket 90 Degree Long Radius Bend  
Length: --  
Manufacturer: TPY Limited

Delivery date: --  
Origin: China

**Laboratory Test Result**  
Date of sample received: 29 May 2017  
Date of test: 06 June 2017

Specimen no.	DP0170529-231	
Testing temperature	22.0 °C	
Pressure amplitude maintained	25 bar	
Actual testing time	Time start	0 sec.
	Time end	15 sec.
	Time interval	15 sec.
Any leakage during the test	No.	
Compliance	C	

Notes: Test sample shall withstand the internal pressure without any leakage to EN598 : 1995.  
Legends: C - Comply with EN598 : 2007 + A1 : 2009.  
\* - Do not comply with EN598 : 2007 + A1 : 2009.  
\* - Only apply to the specimen tested.  
\* - The sample comply with the requirement of BS EN 598 : 2007 + A1 : 2009 Clause 4.7.

Certified by:   
WONG KA MAN  
Sales Manager

End of Report

12 0396

安海街33號 33, On Kai Street, Fanling, Hong Kong. Tel: 2597 8333  
安全街29A號 29A, On Chuen Street, Fanling, Hong Kong. Fax: 2597 8399  
E-mail: info@castco.com.hk Website: www.castco.com.hk

\* and all items with access door made to order.

\* All rights reserved. It is unlawful to copy or extract the whole or the materials from this catalog without the written consent of our company.



祥興鑄鐵有限公司  
CHEUNG HING FOUNDRY (HK) LIMITED



# BS EN 598 Ductile Iron All Socket Fitting With Flexible Joint. (For Sewerage)

## BS EN 598

### 全疏杰柔性膠圈接頭球墨鑄鐵排污配件

## 90° Long Radius Bend - Test Report 90°大彎邊證書

### Brinell Hardness

### Dimension



**CASTCO** 佳力高試驗中心有限公司  
CASTCO TESTING CENTRE LIMITED

**Test Report**  
Brinell Hardness Test of Ductile Iron Pipes, Fittings and Accessories for Sewerage Application  
[BS EN 598 : 2007 + A1 : 2009 Clause 4.3.2]

Date of issue: 1 December 2017  
Page 1 of 1 page(s)  
Castco LRN: DP0170529-231

**Details as supplied by customer:-**  
Customer: TPV Limited  
Address: GF, No. 120, Tung Tau Tsuen, Shap Pat Heung, Yuen Long, N.T.  
Job title: --  
Sample description: --  
Sample I.D.: --  
Nominal size (DN): 100  
Class: --  
Origin: China  
Type: Fitting (All Socket 90 Degree Long Radius Bend)  
Manufacturer: TPV Limited  
Brand:

Brinell hardness testing machine: Machine type: 布氏硬度計HB-3000B Series No.: 0125 (BH01)  
Cert. No.: CL0170518-12 I.D. No.: NDT-HB-01  
Calipers: I.D. No.: NDT-HB-007

**Laboratory test results:-**  
Date of received: 29 May 2017 Date of test: 11 November 2017  
Test specimen thickness: 7.03 mm Test temperature: 26 °C

**Sketch of test locations**

Indentation no.	Indentation diameter (2 directions) (mm)		Indentation means (mm)	Corresponding hardness value (HB)	Results
1	4.61	4.59	4.60	170	C
2	4.59	4.57	4.58	172	C
3	4.54	4.56	4.55	174	C

**CASTCO** 佳力高試驗中心有限公司  
CASTCO TESTING CENTRE LIMITED

**Test Report**  
Method for Determination of Dimensions of Ductile Iron Pipes, Fittings, Accessories and Their Joints for Sewage Applications  
[BS EN 598 : 2007 + A1 : 2009 Clause 4.2 & Clause 4.3.3]

Date of issue: 1 December 2017  
Page 1 of 2 page(s)  
Castco LRN: DP0170529-231 DIM

**Details as supplied by customer:-**  
Customer: TPV Limited  
Address: GF, No. 120, Tung Tau Tsuen, Shap Pat Heung, Yuen Long, N.T.  
Contract no.: --  
Job title: --  
Customer's ref. no.: --  
Description of: --  
Nominal bore: 100 mm  
Brand name:   
Delivery date: --  
Origin: China  
Length: --  
Type: Fitting (All Socket 90 Degree Long Radius Bend)  
Manufacturer: TPV Limited

**Laboratory Test Result**  
Date sample received: 29 May 2017 Date of test: 02 June 2017  
Specimen no. DP0170529-231

Nominal size DN: 100	Test result	BS EN requirement	Customer requirement
External diameter (e) (mm)			
Orality spigot of external diameter (mm)			
Thickness (T) (mm)	6.72	--	7.2
Internal diameter (mm)			
Length (Le1) (mm)	392	--	395
Length (Le2) (mm)	392	--	395
Length (La) (mm)			
Measured thickness of cement mortar lining (mm)	5.6	4 (-1.5)	--

Remarks: 1. Test results relate only to the specimen tested.  
2. Compliance check against BS EN 598: 2007+A1:2009 clause 4.2 was not possible as this fitting could not be found in the standard.

Checked by:   
Certified by:

### Surface Condition

**CASTCO** 佳力高試驗中心有限公司  
CASTCO TESTING CENTRE LIMITED

**Test Report**  
Surface Condition Test for Ductile Iron Pipes, Fittings, Accessories and Their Joints for Sewerage Application  
[BS EN 598 : 2007+A1 : 2009 clause 4.1.2]

Date of issue: 1 December 2017  
Page 1 of 1 page(s)  
Castco LRN: DP0170529-231 SC

**Details as supplied by customer:-**  
Customer: TPV Limited  
Address: GF, No. 120, Tung Tau Tsuen, Shap Pat Heung, Yuen Long, N.T.  
Job title: --  
Sample Description: --  
Sample I.D.: --  
Nominal size (DN): 100  
Manufacturer: TPV Limited  
Brand:   
Origin: China  
Type: Fitting (All Socket 90 Degree Long Radius Bend)  
Nominal length: --

**Laboratory test results:-**  
Date sample received: 29 May 2017 Date of test: 02 June 2017

The external surface condition of test sample is free from defect and surface imperfections.

Remark: 1. Test result relate only to the specimens tested.  
2. Test results complies with Clause 4.1.2 of BS EN 598 : 2007 + A1 : 2009.

Checked by:   
Certified by:

### Tensile

**CASTCO** 佳力高試驗中心有限公司  
CASTCO TESTING CENTRE LIMITED

**Test Report**  
Tensile Test of Ductile Cast Iron  
[BS EN 598 : 2007 + A1 : 2009 Clause 4.3.1]

Date of issue: 16 January 2018  
Page 1A of 1 page  
Castco LRN: DP0170529-231 TEN

**Details as supplied by customer:-**  
Customer: TPV Limited  
Address: GF, No. 120, Tung Tau Tsuen, Shap Pat Heung, Yuen Long, N.T.  
Job title: --  
Sample Description: DN100 All Socket 90 Degree Long Radius Bend  
Grade: --  
Manufacturer: TPV Limited  
Acceptance standard: BS EN598: 2007 + A1 : 2009 Clause 4.3.1  
Brand:   
Origin: China

**Laboratory test results:-**  
Date received: 29 May 2017 Date tested: 11 November 2017

Specimen Mark	Material designation		Gauge dia. (mm)	Cross-sect. area (mm <sup>2</sup> )	Original gauge length (mm)	Final gauge length (mm)	0.2% Proof stress (kN) (MPa)	Tensile Load		Elongation %	Compliance
	Symbol	Number						(kN)	(MPa)		
DP0170529-231	--	--	5.05	20.0	40	45		8.5	424	12.5	C

Remarks: 1. Legends: C = comply with acceptance standard, F = fail to comply with acceptance standard.  
2. Test results relate to the specimen tested only.  
3. Test results comply with requirement of BS EN 598 : 2007 + A1 : 2009 Clause 4.3.1.  
4. This page no. 1A of test report superseded page no. 1 of the previous test report of Castco LRN: DP0170529-231 TEN issued on 1 December 2017.

Checked by:   
Certified by:

18

\* All rights reserved. It is unlawful to copy or extract the whole or the materials from this catalog without the written consent of our company.



祥興鑄鐵有限公司  
CHEUNG HING FOUNDRY (HK) LIMITED