



BS EN 598 Ductile Iron All Socket Fitting With Flexible Joint. (For Sewerage)

BS EN 598

全疏杰柔性膠圈接頭球墨鑄鐵排污配件

Taper Collar Short Pipe with Access Door Flanged Spigots Flanged Sockets



祥興鑄鐵有限公司
CHEUNG HING FOUNDRY (HK) LIMITED



BS EN 598 Ductile Iron All Socket Fitting With Flexible Joint. (For Sewerage)

BS EN 598

全疏杰柔性膠圈接頭球墨鑄鐵排污配件

Collar 梳杰

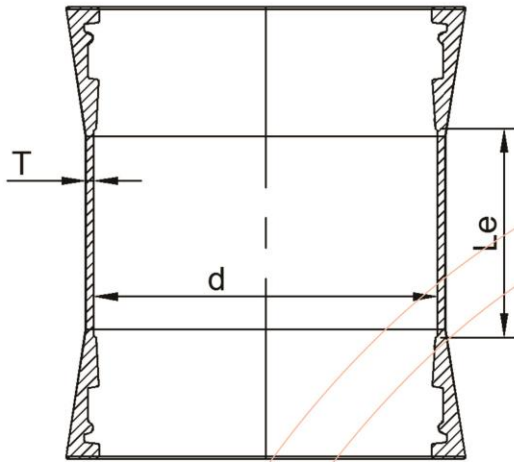

Size	D	Le	T
mm	mm	mm	mm
80	109	160	7.0
100	130	160	7.2
150	183	165	7.8
200	235	170	8.4
250	288	175	9.0
300	340	180	9.6
* 350	393	185	10.2
* 400	445	190	10.8
* 450	498	195	11.4
* 500	550	200	12.0
* 600	655	210	13.2
* 700	760	220	14.4

Collar - Test Report 疏杰證書

* Made to order.

Brinell Hardness

CASTCO 佳力高試驗中心有限公司
CASTCO TESTING CENTRE LIMITED

Test Report
Brinell Hardness Test of Ductile Iron Pipes, Fittings and Accessories for Sewerage Applications
[BS EN 598 : 2007 + A1 : 2009 Clause 4.3.2]

Date of issue : 17 April 2018
Page 1 of 1 page(s)
Castco LRN : DP0180104-080 BH

Details as supplied by customer:
Customer : TPY Ltd.
Address : G/F, No. 120, Tung Tau Tsuen, Shap Pat Heung, Yuen Long, N.T., Hong Kong
Job title : --
Sample description : --
Sample I.D. : --
Nominal size (DN) : 100
Class : --
Origin : China
Type : Fitting (All Socket Collar)
Manufacturer : TPY Ltd.
Brand :

Customer's Ref. No. : --
Contract no. : --

Brinell hardness testing machine : Machine type : 布氏硬度計HB-3000B Series No. : 0125 (BH01)
Cert. No. : CL0170518-12 L.D. No. : NDT-HB-01
Calipers : L.D. No. : NDT-HB-007

Laboratory test results:
Date of received : 04 January 2018 Date of test : 26 January 2018
Test specimen thickness : 23.66 mm Test temperature : 21 °C

Sketch of test locations

Indentation no.	Indentation diameter (2 directions) (mm)	Indentation means (mm)	Corresponding hardness value (HB)	Results
1	4.69	4.76	4.73	161 C
2	4.75	4.64	4.69	164 C
3	4.73	4.80	4.77	158 C

Remark : 1. Test results relate only to the specimen tested.
2. Test results of the sample comply with the requirement of BS EN 598 : 2007 + A1 : 2009.

Checked by :
SIT KWAN NING
Laboratory Supervisor

Certified by :
LEE WAI KWOK
B.Sc., C. Eng., M.C.E., M.C.S.E.
Regional Professional Engineer
Executive Director

From No. PIPE DUCTION WELDRING, PL 01 (19/03/05) 218

香港粉嶺安樂街33號 33, On Kai Street, Fanling, Hong Kong. Tel : 2597 8333
香港粉嶺安全街29A號 29A, On Chuen Street, Fanling, Hong Kong. Fax : 2597 8399
E-mail: info@castco.com.hk Website: www.castco.com.hk

Leaktightness

CASTCO 佳力高試驗中心有限公司
CASTCO TESTING CENTRE LIMITED

Test Report
Work Leaktightness Test of Ductile Iron Pipes, fittings, accessories and their joints for water pipelines
[In accordance to EN598: 2007 + A1 : 2009 Clause 4.7]

Date of issue : 17 April 2018
Page 1 of 1 page
Castco LRN : DP0180104-080 HYD

Details as supplied by customer:
Customer : TPY Ltd.
Address : G/F, No. 120, Tung Tau Tsuen, Shap Pat Heung, Yuen Long, N.T., Hong Kong
Contract No. : --
Job title : --
Description of Fitting : --
Nominal size (DN) : 100
Brand name :
Pressure testing type : Fitting (All Socket Collar)
Length : --
Manufacturer : TPY Ltd.

Delivery date : --

Laboratory Test Result
Date of sample received : 04 January 2018 Date of test : 16 January 2018

Specimen no.	DP0180104-080
Testing temperature	20.0 °C
Pressure amplitude maintained	23 bar
Actual testing time	
Time start	0 sec.
Time end	15 sec.
Time interval	15 sec.
Any leakage during the test	No
Compliance	C

Notes : Test sample shall withstand the internal pressure without any leakage to EN598 : 1995.
Legends : C - Comply with EN598 : 2007 + A1 : 2009.
F - Fail to comply with EN598 : 2007 + A1 : 2009.
Remarks : 1. Test results relate only to the specimen tested.
2. Test results of the sample comply with the requirement of BS EN 598 : 2007 + A1 : 2009 Clause 4.7.

Checked by :
SIT KWAN NING
Laboratory Supervisor

Certified by :
LEE WAI KWOK
B.Sc., C. Eng., M.C.E., M.C.S.E.
Regional Professional Engineer
Executive Director

From No. PIPE DUCTION WELDRING, PL 01 (19/03/05) 218

香港粉嶺安樂街33號 33, On Kai Street, Fanling, Hong Kong. Tel : 2597 8333
香港粉嶺安全街29A號 29A, On Chuen Street, Fanling, Hong Kong. Fax : 2597 8399
E-mail: info@castco.com.hk Website: www.castco.com.hk

* All rights reserved. It is unlawful to copy or extract the whole or the materials from this catalog without the written consent of our company.



祥興鑄鐵有限公司
CHEUNG HING FOUNDRY (HK) LIMITED



BS EN 598 Ductile Iron All Socket Fitting With Flexible Joint. (For Sewerage)

BS EN 598 全疏杰柔性膠圈接頭球墨鑄鐵排污配件

Collar - Test Report 疏杰證書

Dimension

CASTCO 佳力高試驗中心有限公司
CASTCO TESTING CENTRE LIMITED

Test Report
Method for Determination of Dimensions of Ductile Iron Pipes, Fittings, Accessories and Their Joints for Sewage Applications
(BS EN 598 : 2007 + A1 : 2009 Clause 4.2 & Clause 4.4.3)

Date of issue : 17 April 2018
Page 2 of 2 page(s)
Castco LRN : DP0180104-080

Appendix

CASTCO 佳力高試驗中心有限公司
CASTCO TESTING CENTRE LIMITED

Test Report
Method for Determination of Dimensions of Ductile Iron Pipes, Fittings, Accessories and Their Joints for Sewage Applications
(BS EN 598 : 2007 + A1 : 2009 Clause 4.2 & Clause 4.4.3)

Date of issue : 17 April 2018
Page 1 of 2 page(s)
Castco LRN : DP0180104-080 DIM

Details as supplied by customer:
Customer : TPY Ltd.
Address : G/F, No. 120, Tung Tau Tsuen, Shap Pat Heung, Yuen Long, N.T. Hong Kong
Contract No. : --
Job title : --
Description of :
Nominal bore : 100 mm
Brand name :
Delivery date : --
Length : --
Type : Fitting (All Socket Collar)
Manufacturer : TPY Ltd.
Origin : China

Customer's ref. no. : --

Laboratory Test Result
Date sample received : 04 January 2018
Date of test : 16 January 2018
Sample I.D. : DP0180104-080

Nominal size DN :	100	Test result	BS EN requirement	Customer requirement
External diameter (e)	(mm)	--	--	--
Ovality spigot of external diameter	(%)	--	--	--
Thickness (T)	(mm)	7.72	7.2 (-2.4)	7.2
Internal diameter	(mm)	--	--	--
Length (Le)	(mm)	160	160 (+25)	160
Length (d)	(mm)	140	130 (+25)	130
Measured thickness of cement mortar lining	(mm)	--	--	--

Remarks : 1. Test results relates only to the specimen tested.
2. Test results of the sample comply with the requirement of BS EN 598 : 2007 + A1 : 2009 Clause 4.2 & Clause 4.4.3.

Checked by :
SIT KWAN NING
Laboratory Supervisor

Certified by :
LEE WAI KWOK
B.Sc., C. Eng., M.C.E., M.I.M.E.
Registered Professional Engineer
Executive Director

From No. : PPS 1204/10/2005, 1 & 01/10/2011 /18
香港特備安局街33號 33, On Kai Street, Fanling, Hong Kong. Tel : 2597 8333
香港特備安局街29A號 29A, On Chuen Street, Fanling, Hong Kong. Fax : 2597 8399
E-mail : info@castco.com.hk Website : www.castco.com.hk



Surface Condition

CASTCO 佳力高試驗中心有限公司
CASTCO TESTING CENTRE LIMITED

Test Report
Surface Condition Test for Ductile Iron Pipes, Fittings, Accessories and Their Joints for Sewerage Application
(BS EN 598 : 2007 + A1 : 2009 clause 4.1.2)

Date of issue : 17 April 2018
Page 1 of 1 page(s)
Castco LRN : DP0180 04-080 SC

Details as supplied by customer:
Customer : TPY Ltd.
Address : G/F, No. 120, Tung Tau Tsuen, Shap Pat Heung, Yuen Long, N.T. Hong Kong
Job title : --
Sample Description : --
Sample I.D. : --
Nominal size (DN) : 100
Manufacturer : TPY Ltd.
Origin : China
Type : Fitting (All Socket Collar)
Nominal length : --
Brand :

Customer's Ref. No. : --
Contract No. : --

Laboratory test result:
Date sample received : 04 January 2018
Date of test : 16 January 2018

The external surface condition of test sample is free from defect and surface imperfections.

Remark :
1. Test result relate only to the specimens tested.
2. Test results complies with Clause 4.1.2 of BS EN 598 : 2007 + A1 : 2009.

Checked by :
SIT KWAN NING
Laboratory Supervisor

Certified by :
LEE WAI KWOK
B.Sc., C. Eng., M.C.E.
Registered Professional Engineer

From No. : PPS 1204/10/2005, 1 & 01/10/2011 /18
香港特備安局街33號 33, On Kai Street, Fanling, Hong Kong. Tel : 2597 8333
香港特備安局街29A號 29A, On Chuen Street, Fanling, Hong Kong. Fax : 2597 8399
E-mail : info@castco.com.hk Website : www.castco.com.hk

Tensile

CASTCO 佳力高試驗中心有限公司
CASTCO TESTING CENTRE LIMITED

Test Report
Tensile Test of Ductile Cast Iron
(BS EN 598 : 2007 + A1 : 2009 Clause 4.3.1)

Date of issue : 17 April 2018
Page 1 of 1 page
Castco LRN : DP0180104-080 TEN

Details as supplied by customer:
Customer : TPY Ltd.
Address : G/F, No. 120, Tung Tau Tsuen, Shap Pat Heung, Yuen Long, N.T. Hong Kong
Job title : --
Sample Description : DN100 Ductile Iron All Socket Collar
Grade : --
Manufacturer : TPY Ltd.
Brand name :
Acceptance standard : BS EN 598 : 2007 + A1 : 2009 Clause 4.3.1
Origin : China

Customer Ref. No. : --
Contract no. : --

Laboratory test result:
Date received : 04 January 2018
Date tested : 15 February 2018

Specimen Mark	Material designation		Gauge dia. (mm)	Cross-sect. Area, (mm ²)	Original gauge length, (mm)	Final gauge length, (mm)	0.2% Proof stress		Tensile Load (kN)	Elongation %	Compliance	
	Symbol	Number					(kN)	(MPa)				
DP0180104-080	--	--	5.08	29.2	40	44			9.1	450	10	C

Remarks :
1. Legends : C - comply with acceptance standard. F - fail to comply with acceptance standard
2. Test results relate to the specimens tested only.
3. Test results of the sample comply with requirement of BS EN 598 : 2007 + A1 : 2009 Clause 4.3.1.

Checked by :
SIT KWAN NING
Laboratory Supervisor

Certified by :
LEE WAI KWOK
B.Sc., C. Eng., M.C.E., M.I.M.E.
Registered Professional Engineer
Executive Director

From No. : STL 06/2005/2005/01 & 01/10/2011 /18

* All rights reserved. It is unlawful to copy or extract the whole or the materials from this catalog without the written consent of our company.



祥興鑄鐵有限公司
CHEUNG HING FOUNDRY (HK) LIMITED



BS EN 598 Ductile Iron All Socket Fitting With Flexible Joint. (For Sewerage)

BS EN 598

全疏杰柔性膠圈接頭球墨鑄鐵排污配件

Taper - Test Report 刁士證書

Brinell Hardness

Dimension



CASTCO 佳力高試驗中心有限公司
CASTCO TESTING CENTRE LIMITED

Test Report
Brinell Hardness Test of Ductile Iron Pipes, Fittings and Accessories for Sewerage Application
[BS EN 598 : 2007 + A1 : 2009 Clause 4.3.2]

Date of issue : 17 May 2018
Page 1A of 1 page(s)
Castco LRN : DP0180104-086

Details as supplied by customer:
Customer : TPY Ltd.
Address : GF., No. 120, Tung Tau Tsuen, Shap Pat Heung, Yuen Long, N.T. Hong Kong
Job title : ---
Sample description :-
Sample LD. :-
Nominal size (DN) : 100 x 150
Class :-
Origin : China

Type : Fitting (All Socket Taper)
Manufacturer : TPY Ltd.
Brand :

Machine type : 布氏硬度計 HB-3000B
Cert. No. : CL070518-12
L.D. No. : NDT-HB-007

Series No. : 0125 (BH01)
L.D. No. : NDT-HB-01

Brinell hardness testing machine
Calipers

Date of received : 04 January 2018
Date of test : 26 January 2018
Test specimen thickness : 23.47 mm
Test temperature : 21 °C

Sketch of test locations

1	2	3
O	O	O

Indentation no.	Indentation diameter (2 directions) (mm)	Indentation means (mm)	Corresponding hardness value (HB)	Result	
1	4.65	4.54	4.60	170	C
2	4.67	4.62	4.65	167	C
3	4.59	4.63	4.61	170	C

Remark : 1. Test results relate only to the specimen tested.
2. Test results of the sample comply with the requirement of BS EN 598 : 2007 + A1 : 2009.

CASTCO 佳力高試驗中心有限公司
CASTCO TESTING CENTRE LIMITED

Test Report
Method for Determination of Dimensions of Ductile Iron Pipes, Fittings, Accessories and Their Joints for Sewerage Applications
[BS EN 598 : 2007 + A1 : 2009 Clause 4.2 & Clause 4.4.3]

Date of issue : 17 May 2018
Page 1A of 2 page(s)
Castco LRN : DP0180104-086 DIM

Details as supplied by customer:
Customer : TPY Ltd.
Address : GF., No. 120, Tung Tau Tsuen, Shap Pat Heung, Yuen Long, N.T. Hong Kong
Job title : ---
Contract no. :-
Description of :-
Nominal bore : 100 x 150 mm
Length :-
Brand name :
Delivery date :-
Type : Fitting (All Socket Taper)
Manufacturer : TPY Ltd.
Origin : China

Laboratory Test Result
Date sample received : 04 January 2018
Date of test : 17 January 2018
Sample LD. : DP0180104-086

Nominal size DN : 100 x 150	Test result	BS EN requirement	Customer requirement
External diameter (e)	(mm)	--	--
Quality spigot of external diameter	(%)	--	--
Thickness (T)	(mm)	8.35	7.8 (-2.45)
Internal diameter	(mm)	--	--
Thickness (t1)	(mm)	8.04	7.2 (-2.40)
Length (L±2)	(mm)	150	150 (+25)
Measured thickness of cement mortar lining	(mm)	12.41	4(-1.5)

Remarks : 1. Test results relate only to the specimen tested.
2. Test results of the sample comply with the requirement of BS EN 598 : 2007 + A1 : 2009 Clause 4.2 & Clause 4.4.3.
3. This page no. 1A of test report superseded page no. 1 of the previous test report of Castco LRN : DP0180104-086 DIM issued on 17 April 2018.

Checked by :
SIT KWAN NING
Laboratory Supervisor

End of Report

WONG KA MAN
Senior Manager

Castco LRN : DP0180104-086 DIM

香港新界安老街33號 33, On Kai Street, Fanling, Hong Kong. Tel : 2597 8333
香港新界安老街29A號 29A, On Chuen Street, Fanling, Hong Kong. Fax : 2597 8399
E-mail : info@castco.com.hk Website : www.castco.com.hk

Surface Condition

CASTCO 佳力高試驗中心有限公司
CASTCO TESTING CENTRE LIMITED

Test Report
Surface Condition Test for Ductile Iron Pipes, Fittings, Accessories and Their Joints for Sewerage Application
[BS EN 598 : 2007 + A1 : 2009 clause 4.1.3]

Date of issue : 17 May 2018
Page 1A of 1 page(s)
Castco LRN : DP0180104-086 SC

Details as supplied by customer:
Customer : TPY Ltd.
Address : GF., No. 120, Tung Tau Tsuen, Shap Pat Heung, Yuen Long, N.T. Hong Kong
Job title : ---
Sample Description :-
Sample LD. :-
Nominal size (DN) : 100 x 150
Manufacturer : TPY Ltd.
Origin : China

Type : Fitting (All Socket Taper)
Nominal length :-
Brand :

Date sample received : 04 January 2018
Date of test : 16 January 2018

The external surface condition of test sample is free from defect and surface imperfections.

Remark : 1. Test result relate only to the specimen tested.
2. Test results complies with Clause 4.1.2 of BS EN 598 : 2007 + A1 : 2009.
3. This test report superseded previous test report of Castco LRN : DP0180104-086 SC issued on 17 April 2018.

Checked by :
SIT KWAN NING
Laboratory Supervisor

End of Report

WONG KA MAN
Senior Manager

Castco LRN : DP0180104-086 SC

香港新界安老街33號 33, On Kai Street, Fanling, Hong Kong. Tel : 2597 8333
香港新界安老街29A號 29A, On Chuen Street, Fanling, Hong Kong. Fax : 2597 8399
E-mail : info@castco.com.hk Website : www.castco.com.hk

Tensile

CASTCO 佳力高試驗中心有限公司
CASTCO TESTING CENTRE LIMITED

Test Report
Tensile Test of Ductile Cast Iron
[BS EN 598 : 2007 + A1 : 2009 Clause 4.3.1]

Date of issue : 17 May 2018
Page 1A of 1 page
Castco LRN : DP0180104-086 TEN

Details as supplied by customer:
Customer : TPY Ltd.
Address : GF., No. 120, Tung Tau Tsuen, Shap Pat Heung, Yuen Long, N.T. Hong Kong
Job title : ---
Sample Description : DN100 x 150 Ductile Iron All Socket Taper
Grade :-
Manufacturer : TPY Ltd.
Acceptance standard : BS EN 598 : 2007 + A1 : 2009 Clause 4.3.1
Brand name :
Origin : China

Date received : 04 January 2018
Date tested : 15 February 2018

Specimen Mark	Material designation		Gauge dia. (mm)	Cross-sect. Area, (mm ²)	Original gauge length, (mm)	Final gauge length, (mm)	0.2% Proof stress		Tensile Load (kN)	Elongation %	Compliance
	Symbol	Number					(kN)	(MPa)			
DP0180104-086	--	--	5.11	20.5	40	44		9.5	464	10	C

Remarks :-
1. Legends : C - comply with acceptance standard. F - fail to comply with acceptance standard
2. Test results relate to the specimen tested only.
3. Test results of the sample comply with requirement of BS EN 598 : 2007 + A1 : 2009 Clause 4.3.1.
4. This test report superseded previous test report of Castco LRN : DP0180104-086 TEN issued on 17 April 2018.

Checked by :
SIT KWAN NING
Laboratory Supervisor

End of Report

WONG KA MAN
Senior Manager

Castco LRN : DP0180104-086 TEN

香港新界安老街33號 33, On Kai Street, Fanling, Hong Kong. Tel : 2597 8333
香港新界安老街29A號 29A, On Chuen Street, Fanling, Hong Kong. Fax : 2597 8399
E-mail : info@castco.com.hk Website : www.castco.com.hk

* All rights reserved. It is unlawful to copy or extract the whole or the materials from this catalog without the written consent of our company.



祥興鑄鐵有限公司
CHEUNG HING FOUNDRY (HK) LIMITED



BS EN 598 Ductile Iron All Socket Fitting With Flexible Joint. (For Sewerage)

BS EN 598

全疏杰柔性膠圈接頭球墨鑄鐵排污配件

Short Pipe with Access Door

有口短坭

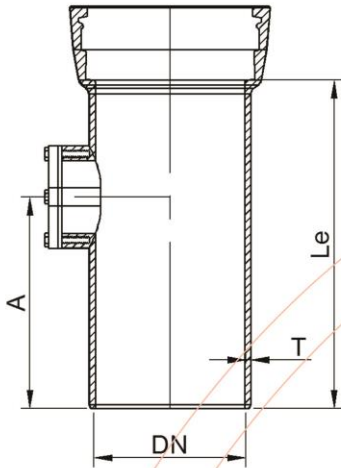

Size	DN	A	Le	T
mm	mm	mm	mm	mm
100	100	270	400	7.2
150	150	270	400	7.8
200	200	290	450	8.4
250	250	280	450	9.0
300	300	280	450	9.6

Short Pipe with Access Door - Test Report 有口短坭證書

Brinell Hardness

CASTCO 佳力高試驗中心有限公司
CASTCO TESTING CENTRE LIMITED

Test Report
Brinell Hardness Test of Ductile Iron Pipes, Fittings and Accessories for Sewerage Applications
[BS EN 598 : 2007 + A1 : 2009 Clause 4.3.2]

Date of issue : 17 April 2018
Page 1 of 1 page(s)
Castco LRN : DP0180104-090 BH

Details as supplied by customer:
Customer : TPY Ltd.
Address : G/F., No. 120, Tung Tau Tsuen, Shap Pat Heung, Yeun Long, N.T., Hong Kong
Job title : --
Sample description : --
Sample I.D. : --
Nominal size (DN) 100
Class : --
Origin : China
Type : Fitting (Socket Spigot Short Pipe with Access Door)
Manufacturer : TPY Ltd.
Brand :

Customer's Ref. No. : --
Contract no. : --

Brinell hardness testing machine : Machine type : 布氏硬機計HB-3000B Series No. : 0125 (BH01)
Cert. No. : CL0178518-12 I.D. No. : NDT-HB-01
Calipers : L.D. No. : NDT-HB-007

Laboratory test results:
Date of received : 04 January 2018 Date of test : 26 January 2018
Test specimen thickness : 24.18 mm Test temperature : 21 °C

Sketch of test locations

Indentation no.	Indentation diameter (2 directions) (mm)	Indentation means (mm)	Corresponding hardness value (HB)	Results
1	4.73	4.72	161	C
2	4.75	4.71	160	C
3	4.71	4.74	160	C

Remark : 1. Test results relates only to the specimen tested.
2. Test results of the sample comply with the requirement of BS EN 598 : 2007 + A1 : 2009.

Checked by :
SIT KWAN NING
Laboratory Supervisor

End of Report

Certified by :
LEE WAI KWOK
B.Sc., Eng., M.C.S., M.I.M.E.
Registered Professional Engineer
Executive Director

Form No. PIPE DUCTION WELDRING, T 01 (1/2012)

Leaktightness

CASTCO 佳力高試驗中心有限公司
CASTCO TESTING CENTRE LIMITED

Test Report
Work Leaktightness Test of Ductile Iron Pipes, fittings, accessories and their joints for water pipelines
[In accordance to EN598: 2007 + A1 : 2009 Clause 4.7]

Date of issue : 17 April 2018
Page 1 of 1 page
Castco LRN : DP0180104-090 HYD

Details as supplied by customer:
Customer : TPY Ltd.
Address : G/F., No. 120, Tung Tau Tsuen, Shap Pat Heung, Yeun Long, N.T., Hong Kong
Job title : --
Description of Fitting : --
Nominal size (DN) : 100
Length : --
Brand name :
Manufacturer : TPY Ltd.
Pressure testing type : Fitting (Socket Spigot Short Pipe with Access Door)

Customer's ref. no. : --
Contract no. : --

Delivery date : --

Laboratory Test Result
Date of sample received : 04 January 2018 Date of test : 18 January 2018

Specimen no.	DP0180104-090
Testing temperature	20.0 °C
Pressure amplitude maintained	25 bar
Actual testing time	Time start : 0 sec. Time end : 15 sec. Time interval : 15 sec.
Any leakage during the test	No
Compliance	C

Notes : Test sample shall withstand the internal pressure without any leakage to EN598 : 1995.
Legends : C - Comply with EN598 : 2007 + A1 : 2009.
F - Fail to comply with EN598 : 2007 + A1 : 2009.
Remarks : 1. Test results relate only to the specimen tested.
2. Test results of the sample comply with the requirement of BS EN 598 : 2007 + A1 : 2009 Clause 4.7.

Checked by :
SIT KWAN NING
Laboratory Supervisor

End of Report

Certified by :
LEE WAI KWOK
B.Sc., Eng., M.C.S., M.I.M.E.
Registered Professional Engineer
Executive Director

Form No. PIPE DUCTION WELDRING, T 01 (1/2012)

* All rights reserved. It is unlawful to copy or extract the whole or the materials from this catalog without the written consent of our company.



祥興鑄鐵有限公司
CHEUNG HING FOUNDRY (HK) LIMITED



BS EN 598 Ductile Iron All Socket Fitting With Flexible Joint. (For Sewerage)

BS EN 598

全疏杰柔性膠圈接頭球墨鑄鐵排污配件

Short Pipe with Access Door - Test Report 有口短坭證書

Dimension



CASTCO 佳力高試驗中心有限公司
CASTCO TESTING CENTRE LIMITED

Test Report
Method for Determination of Dimensions of Ductile Iron Pipes, Fittings, Accessories and Their Joints for Sewerage Applications
(BS EN 598 : 2007 + A1 : 2009 Clause 4.2 & Clause 4.4.3)

Date of issue: 17 April 2018
Page 2 of 2 page(s)
Castco LRN : DP0180104-090

Appendix

CASTCO 佳力高試驗中心有限公司
CASTCO TESTING CENTRE LIMITED

Test Report
Method for Determination of Dimensions of Ductile Iron Pipes, Fittings, Accessories and Their Joints for Sewerage Applications
(BS EN 598 : 2007 + A1 : 2009 Clause 4.2 & Clause 4.4.3)

Date of issue: 17 April 2018
Page 1 of 2 page(s)
Castco LRN : DP0180104-090 DIM

Details as supplied by customer:
Customer: TPY Ltd.
Address: G/F, No. 120, Tung Tau Tsuen, Shap Pat Heung, Yuen Long, N.T. Hong Kong
Contract No.: --
Job title: --
Description of: --
Nominal bore: 100 mm
Length: --
Brand name: Type: Fitting (Socket Spigot Short Pipe with Access Door)
Delivery date: --
Manufacturer: TPY Ltd.
Origin: China

Customer's ref. no.: --

Laboratory Test Result
Date sample received: 04 January 2018
Date of test: 16 January 2018
Sample I.D.: DP0180104-090

Nominal size DN :	100	Test result	BS EN requirement	Customer requirement
External diameter (e)	(mm)	--	--	--
Quality spigot of external diameter	(%)	--	--	--
Thickness (T)	(mm)	7.1	--	7.2
Internal diameter	(mm)	--	--	100
Length (A)	(mm)	270	--	270
Length (Le)	(mm)	400	--	400
Measured thickness of cement mortar lining	(mm)	13/88	4 (-1.5)	--

Remarks: 1. Test results relate only to the specimen tested.
2. Test results of the sample comply with the requirements of BS EN 598 : 2007 + A1 : 2009 Clause 4.2 & Clause 4.4.3.

Checked by:
SIT KWAN NING
Laboratory Supervisor

Certified by:
LEE WAI KWOK
B.Sc., C. Eng., MICE, MIEAEE
Registered Professional Engineer
Executive Director

End of Report

From No. PPS 62196 (2009) 2 & 10 (2013) 218
香港靜靈安街33號 33, On Kwi Street, Fanling, Hong Kong. Tel: 2597 8333
香港靜靈安街29A號 29A, On Chuen Street, Fanling, Hong Kong. Fax: 2597 8399
E-mail: info@castco.com.hk Website: www.castco.com.hk

Surface Condition

CASTCO 佳力高試驗中心有限公司
CASTCO TESTING CENTRE LIMITED

Test Report
Surface Condition Test for Ductile Iron Pipes, Fittings, Accessories and Their Joints for Sewerage Application
(BS EN 598 : 2007+A1 : 2009 clause 4.1.2)

Date of issue: 17 April 2018
Page 1 of 1 page(s)
Castco LRN : DP0180104-090 SC

Details as supplied by customer:
Customer: TPY Ltd.
Address: G/F, No. 120, Tung Tau Tsuen, Shap Pat Heung, Yuen Long, N.T. Hong Kong
Contract No.: --
Job title: --
Sample Description: --
Sample I.D.: --
Nominal size (DN): 100
Manufacturer: TPY Ltd.
Origin: China

Customer's Ref. No.: --
Contract No.: --

Type: Fitting (Socket Spigot Short Pipe)
Nominal length: --
Brand:

Date of issue: 17 April 2018
Page 1 of 1 page
Castco LRN : DP0180104-090 TEN

Details as supplied by customer:
Customer: TPY Ltd.
Address: G/F, No. 120, Tung Tau Tsuen, Shap Pat Heung, Yuen Long, N.T. Hong Kong
Contract No.: --
Job title: --
Sample Description: DN100 Ductile Iron Socket Spigot Short Pipe with Access Door
Grade: --
Manufacturer: TPY Ltd.
Brand name:
Acceptance standard: BS EN 598 : 2007+A1 : 2009 Clause 4.3.1
Origin: China

Customer Ref. No.: --
Contract No.: --

Laboratory test results:
Date received: 04 January 2018
Date of test: 16 January 2018

The external surface condition of test sample is free from defect and surface imperfections.

Remark:
1. Test result relate only to the specimens tested.
2. Test results complies with Clause 4.1.2 of BS EN 598 : 2007 + A1 : 2009.

Checked by:
SIT KWAN NING
Laboratory Supervisor

Certified by:
LEE WAI KWOK
B.Sc., C. Eng.
Registered Professional Engineer

End of Report

From No. PPS 62196 (2009) 2 & 10 (2013) 218

香港靜靈安街33號 33, On Kwi Street, Fanling, Hong Kong. Tel: 2597 8333
香港靜靈安街29A號 29A, On Chuen Street, Fanling, Hong Kong. Fax: 2597 8399
E-mail: info@castco.com.hk Website: www.castco.com.hk

Tensile

CASTCO 佳力高試驗中心有限公司
CASTCO TESTING CENTRE LIMITED

Test Report
Tensile Test of Ductile Cast Iron
(BS EN 598 : 2007 + A1 : 2009 Clause 4.3.1)

Date of issue: 17 April 2018
Page 1 of 1 page
Castco LRN : DP0180104-090 TEN

Details as supplied by customer:
Customer: TPY Ltd.
Address: G/F, No. 120, Tung Tau Tsuen, Shap Pat Heung, Yuen Long, N.T. Hong Kong
Contract No.: --
Job title: --
Sample Description: DN100 Ductile Iron Socket Spigot Short Pipe with Access Door
Grade: --
Manufacturer: TPY Ltd.
Brand name:
Acceptance standard: BS EN 598 : 2007+A1 : 2009 Clause 4.3.1
Origin: China

Customer Ref. No.: --
Contract No.: --

Laboratory test results:
Date received: 04 January 2018
Date tested: 15 February 2018

Specimen Mark	Material designation	Gauge dia. (mm)	Cross-sect. Area, (mm ²)	Original gauge length, (mm)	Final gauge length, (mm)	0.2% Proof stress (kN) (MPa)	Tensile Load (kN) (MPa)	Elongation %	Compliance
DP0180104-090	--	5.16	20.9	40	44		10.1 483	10	C

Remarks: --

1. Legends: C - comply with acceptance standard. F - fail to comply with acceptance standard
2. Test results relate to the specimen tested only.
3. Test results of the sample comply with requirement of BS EN 598 : 2007 + A1 : 2009 Clause 4.3.1.

Checked by:
SIT KWAN NING
Laboratory Supervisor

Certified by:
LEE WAI KWOK
B.Sc., C. Eng., MICE, MIEAEE
Registered Professional Engineer
Executive Director

End of Report

From No. PPS 62196 (2009) 2 & 10 (2013) 218

香港靜靈安街33號 33, On Kwi Street, Fanling, Hong Kong. Tel: 2597 8333
香港靜靈安街29A號 29A, On Chuen Street, Fanling, Hong Kong. Fax: 2597 8399
E-mail: info@castco.com.hk Website: www.castco.com.hk

* All rights reserved. It is unlawful to copy or extract the whole or the materials from this catalog without the written consent of our company.



祥興鑄鐵有限公司
CHEUNG HING FOUNDRY (HK) LIMITED



BS EN 598 Ductile Iron All Socket Fitting With Flexible Joint. (For Sewerage)
BS EN 598
 全疏杰柔性膠圈接頭球墨鑄鐵排污配件

Flanged Spigats
佛冷坳尾

(Flanged PN 16)

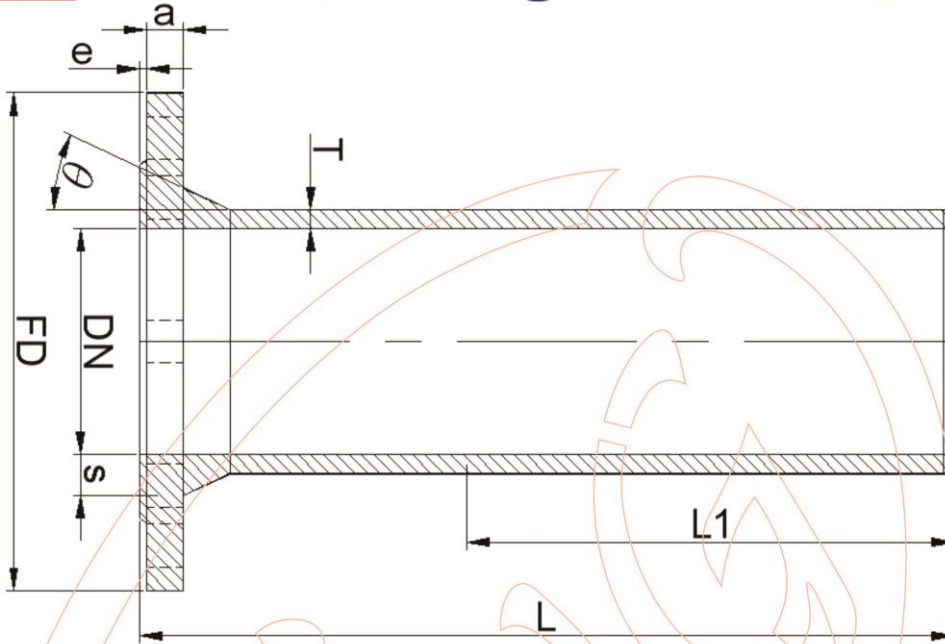

Size	DN	L	L1	T	FD	a	e	s	θ
mm	mm	mm	mm	mm	mm	mm	mm	mm	mm
80	80	350	215	7.0	200	19	3	15	25
100	100	360	215	7.2	220	19	3	15	25
150	150	380	225	7.8	285	19	3	15	25
200	200	400	230	8.4	340	20	3	16	25
250	250	420	240	9.0	400	22	3	17.5	25
300	300	440	250	9.6	455	24.5	4	19.5	25
350	350	460	260	10.2	520	26.5	4	21	25
400	400	480	270	10.8	580	28	4	22.5	25
450	450	500	280	11.4	640	30	4	24	25
500	500	520	290	12.0	715	31.5	4	25	25
600	600	560	310	13.2	840	36	5	29	25
700	700	600	330	14.4	910	39.5	5	29.5	25

All size " Made to order ".

* All rights reserved. It is unlawful to copy or extract the whole or the materials from this catalog without the written consent of our company.

25



祥興鑄鐵有限公司
 CHEUNG HING FOUNDRY (HK) LIMITED



BS EN 598 Ductile Iron All Socket Fitting With Flexible Joint. (For Sewerage)
BS EN 598
 全疏杰柔性膠圈接頭球墨鑄鐵排污配件

Flanged Sockets
 佛冷梳杰

(Flanged PN 16)

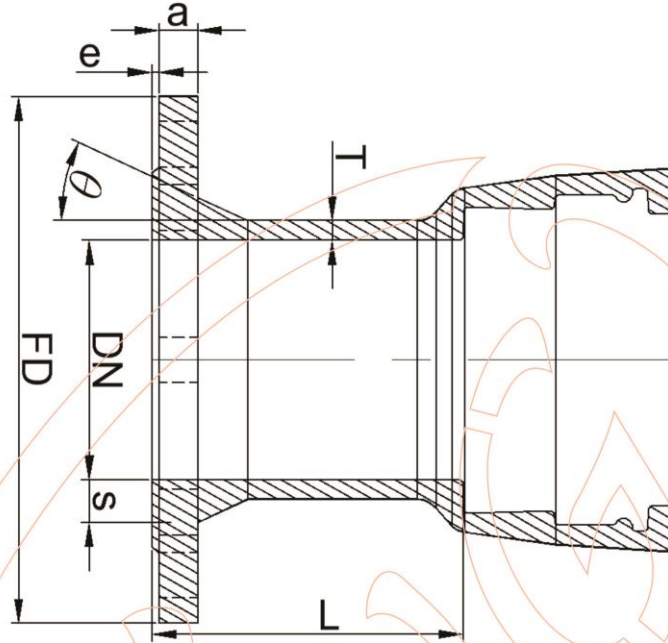

Size	DN	L	T	FD	a	e	s	θ
mm	mm	mm	mm	mm	mm	mm	mm	mm
80	80	130	7.0	200	19	3	15	25
100	100	130	7.2	220	19	3	15	25
150	150	135	7.8	285	19	3	15	25
200	200	140	8.4	340	20	3	16	25
250	250	145	9.0	400	22	3	17.5	25
300	300	150	9.6	455	24.5	4	19.5	25
350	350	155	10.2	520	26.5	4	21	25
400	400	160	10.8	580	28	4	22.5	25
450	450	165	11.4	640	30	4	24	25
500	500	170	12.0	715	31.5	4	25	25
600	600	180	13.2	840	36	5	29	25
700	700	190	14.4	910	39.5	5	29.5	25

Made to order.

* All rights reserved. It is unlawful to copy or extract the whole or the materials from this catalog without the written consent of our company.



祥興鑄鐵有限公司
 CHEUNG HING FOUNDRY (HK) LIMITED



祥興鑄鐵有限公司
CHEUNG HING FOUNDRY (HK) LIMITED

Address : 299 Pak Sha Tsuen Kung Um Road, Yuen Long, H.K.

廠址：香港元朗公庵路白沙村 299 號

Tel : (852) 2447-1262 Fax : (852) 2447-0198

Email : chf@chfhk.com <http://www.chfhk.com>