

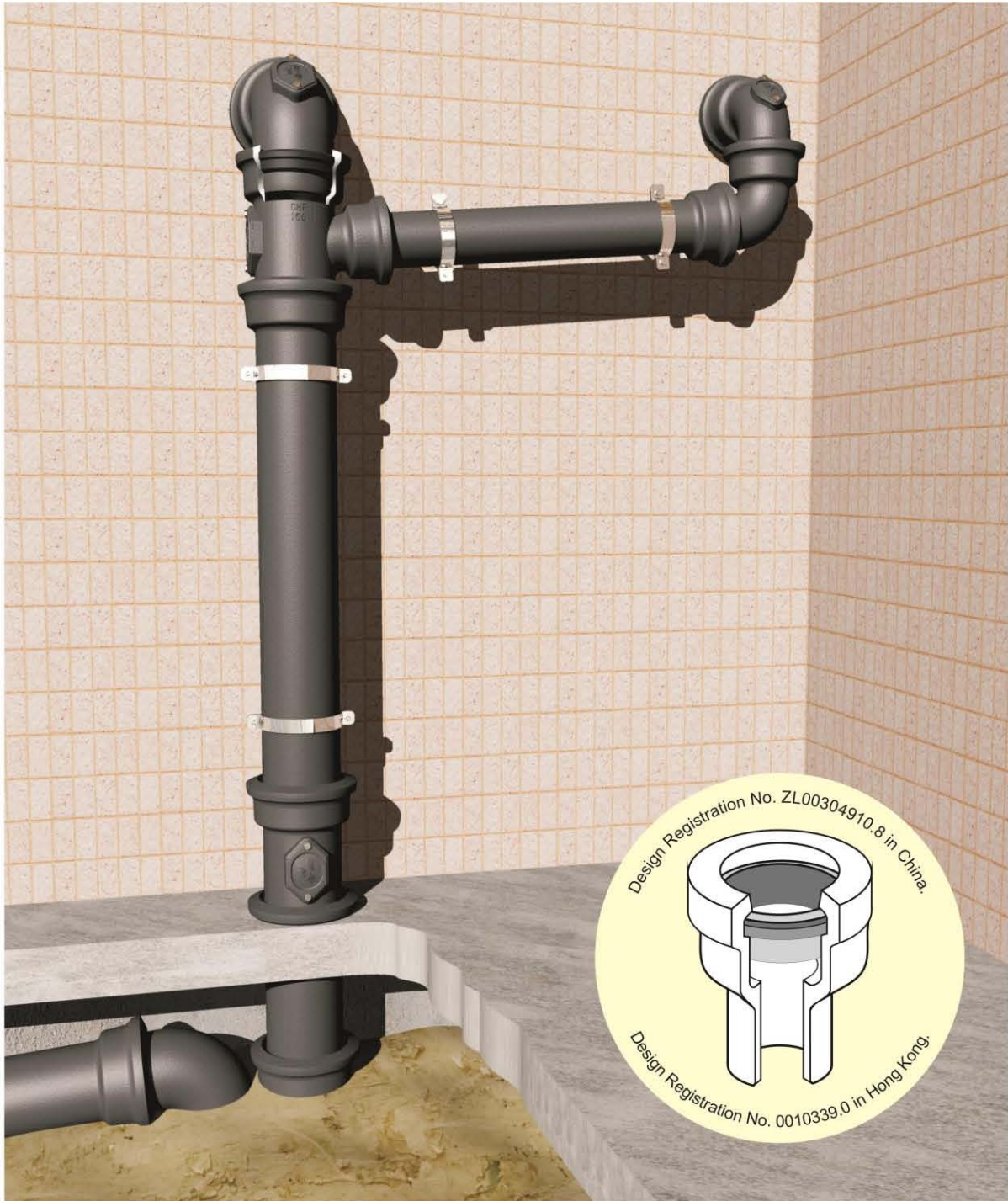

# Eco-Grey / Cast Iron Fittings with Flexible Joint

Nominal Bore: 75-450mm



祥興鑄鐵有限公司  
CHEUNG HING FOUNDRY (HK) LIMITED

**CHF-**  **環保鑄鐵膠圈配件**  
**Eco-Grey/Cast Iron Fittings with Flexible Joint**

**目錄**

TABLE OF CONTENTS

Page

1. .... Introduction



2. ...  Registration of Design

3. .... Installation

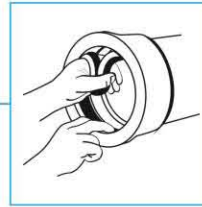

4. ...  Bend, 95°

5. ... Bend, 45°

6. ... Bend, Large Radius, 300R & 400R

7. ...  Reducer

Socket

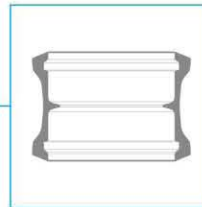

8. ...  Short Connecting Pipe

9. .... Tee, 95°

10. .... Tee, 45°



11. .... Trap

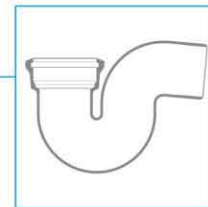

# INTRODUCTION

## CHF<sup>®</sup> Grey/Cast Iron Spigot And Socket Fittings With Flexible Joint

This catalog gives dimensional information and method of jointing for the standard range of our grey/cast iron fittings with push-in flexible joint for discharge of surface and under ground sewage.



### Adaptability to Market Demand

Please note that this range of fittings with flexible joint differs in some respects from that contained in the relevant British Standard namely BS4622. Modifications have been made and new specifications have been introduced to suit the general market demands of Hong Kong and the complex requirements of the local plumbing and drainage industries. Therefore, this factor should be taken into consideration when designing pipeline systems.

### Characteristics of Push-in Flexible Joint

Push-in flexible joint is labor-saving and time-saving, thus more economical than the traditional lead-caulked or mechanical joint. It also allows flexibility to each joint of the entire pipeline systems after full installation. This greatly reduces some of the possible damages done to the pipeline systems as a result of the settlement of top soil and foundations of building structures, which were commonly found on newly-reclaimed land.

### Material

The BS 437 & BS 4622 to fittings of cast iron comply with BSEN1561:1997, EN - GJL - 150.

## 簡 介

### CHF<sup>®</sup> 承插式、柔性膠圈配件

本產品目錄主要介紹由本公司設計及生產的承插式、柔性膠圈接頭鑄鐵配件，並提供詳細尺寸資料及接駁方法。此類配件適用於地面及地底的排污管道上。

### 迎合市場需要及行業要求

為迎合本地市場的獨特需要，及符合本地水喉渠務行業的複雜要求，本司致力改良這一系列膠圈配件的規格及設計，使能與BS437及BS4622壓力管及配件互相配套使用。

### 方便省時的接駁方法

與傳統打黑鉛及機械性接駁方法相比，柔性膠圈接駁方法更方便省時，合乎經濟效益，又容許每個接口有輕微的移動彈性。縱使在新填海區土質尚未堅固、地基有輕微下陷時，也可減少對管道系統造成損害。

註冊外觀設計專利

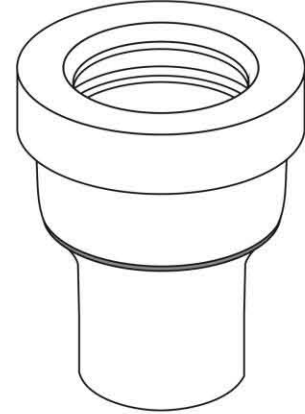

Front view of the pipe

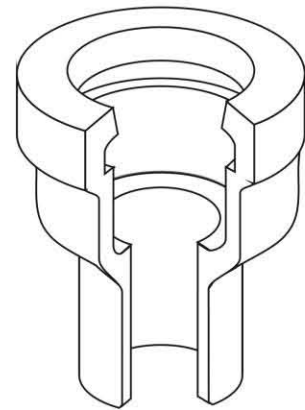
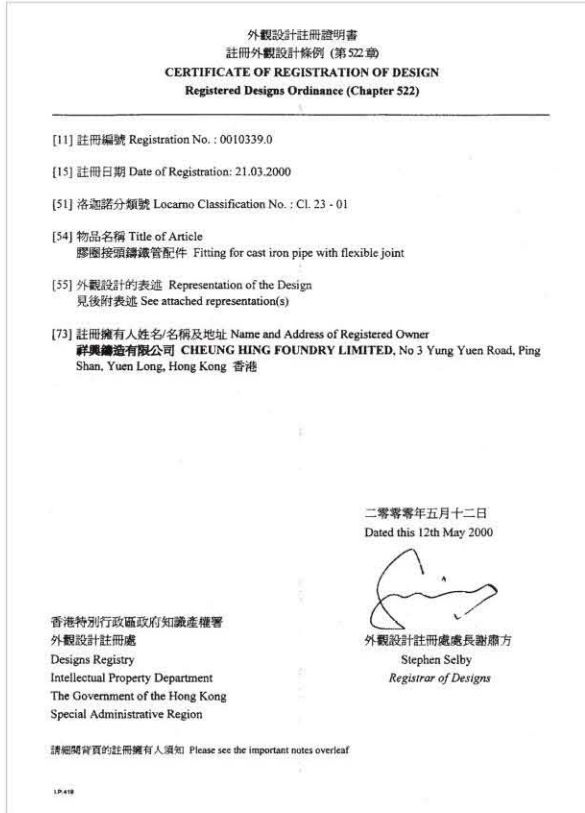

Perspective of the pipe



Front view of the ring

Note: All drawings are for reference only. (NOT TO SCALE)

Users must refer to individual products for actual design and pattern.

注意：以上圖表及尺寸，只供參考。所有尺寸、款式、規格均以實物為準。

All rights reserved. It is unlawful to copy or extract the whole or part of the materials from this catalog without the written consent of CHEUNG HING FOUNDRY (HK) LIMITED.

Installation of Grey/Cast Iron Pipes and Fittings with Flexible Joint  
鑄鐵膠圈壓力管及配件的接駁方法

先用鋼刷徹底清潔垌頭內部及垌尾表面



套上膠圈



套不同尺寸膠圈的安裝，分別有

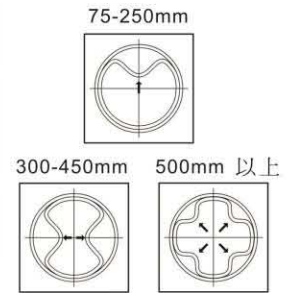

在垌頭內膠圈接觸面及垌尾油上水溶性或無污染潤滑劑



量度垌頭內深度並在垌尾平衡畫上深度線



將兩支垌對齊成一直線及水平線要平衡



用繩索及手動起重工具將兩支垌網綁，然後將垌尾拉入垌頭內



垌尾部份畫有深度線位置完全拉入垌頭內



配件的安裝



垌的安裝

1.1 BEND, 95°  
95° 邊

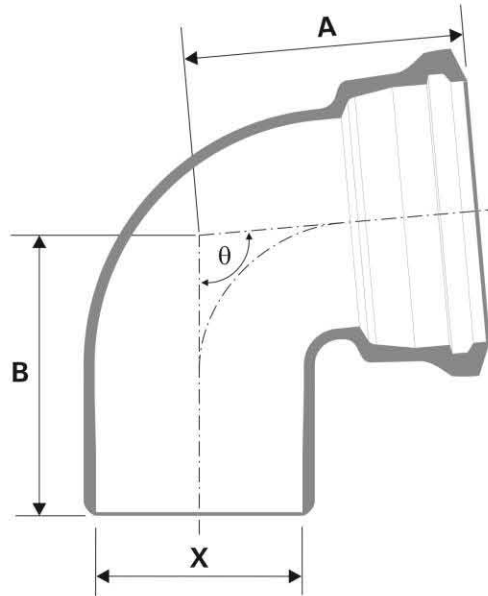

Code No. 貨號	Nominal Diameter 公稱內徑 (mm)	Dimension 尺寸 (mm)			
		A	B	X	θ
RC075A	75	155	155	75	95°
RC100A	100	175	175	100	95°
RC150A	150	205	205	150	95°
RC200A	200	240	260	200	95°
RC225A	225	250	250	225	95°
RC250A	250	285	285	250	95°
RC300A	300	310	310	300	95°
* RC350A	350	357	357	350	95°
* RC375A	375	376	376	375	95°
* RC400A	400	390	390	400	95°
* RC450A	450	415	415	450	95°
* RC500A	500	440	440	500	95°

Bends with access door are available upon request.

\* Made to order

Note: All drawings are for reference only. (NOT TO SCALE)

Users must refer to individual products for actual design and pattern.

注意：以上圖表及尺寸，只供參考。所有尺寸、款式、規格均以實物為準。

All rights reserved. It is unlawful to copy or extract the whole or part of the materials from this catalog without the written consent of CHEUNG HING FOUNDRY (HK) LIMITED.

1.2 BEND, 45°  
45° 邊

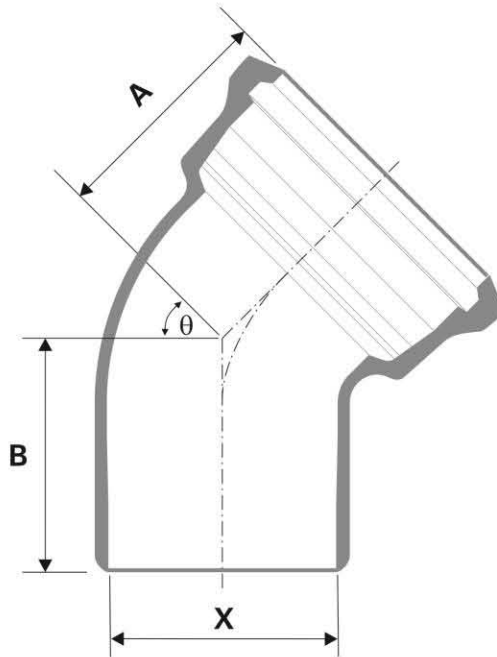

Code No. 貨號	Nominal Diameter 公稱內徑 (mm)	Dimension 尺寸 (mm)			
		A	B	X	Θ
RB075A	75	130	140	75	45°
RB100A	100	140	140	100	45°
RB150A	150	155	155	150	45°
* RB200A	200	175	195	200	45°
RB225A	225	180	180	225	45°
RB300A	300	206	206	300	45°
* RB350A	350	237	237	350	45°
* RB375A	375	250	250	375	45°
* RB400A	400	257	257	400	45°
* RB450A	450	270	270	450	45°
* RB600A	600	325	325	600	45°

Bends with access door are available upon request.

\* Made to order

Note: All drawings are for reference only. (NOT TO SCALE)

Users must refer to individual products for actual design and dimension.

注意：以上圖表及尺寸，只供參考。所有尺寸、款式、規格均以實物為準。

All rights reserved. It is unlawful to copy or extract the whole or part of the materials from this catalog without the written consent of CHEUNG HING FOUNDRY (HK) LIMITED.

1.3 BEND, 95° 300R, 400R & 600R LARGE RADIUS  
95° 300R 400R & 600R 大彎邊

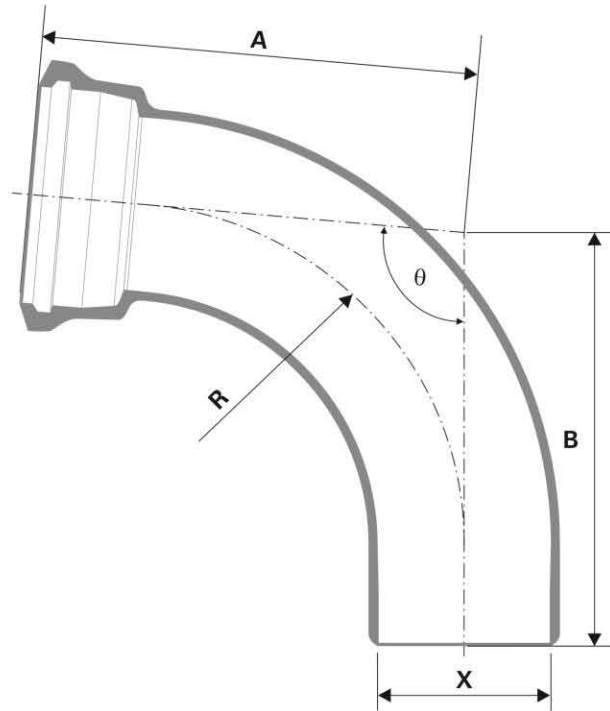

Code No. 貨號	Nominal Diameter 公稱內徑 (mm)	Dimension 尺寸 (mm)				
		A	B	X	R	θ
RD100A	100	380	370	100	300	95°
RD150A	150	386	365	150	300	95°
* RD200A	200	395	385	200	300	95°
* RD225A	225	485	475	225	400	95°
* RD300A	300	530	520	300	400	95°
* RE100A	100	654	640	100	600	95°
* RE150A	150	660	645	150	600	95°
* RE225A	225	680	650	225	600	95°
* RE300A	300	673	650	300	600	95°
* RE375A	375	685	660	375	600	95°

\* Made to order

Note: All drawings are for reference only. (NOT TO SCALE)

Users must refer to individual products for actual design and pattern.

注意：以上圖表及尺寸，只供參考。所有尺寸、款式、規格均以實物為準。

All rights reserved. It is unlawful to copy or extract the whole or part of the materials from this catalog without the written consent of CHEUNG HING FOUNDRY (HK) LIMITED.

Grey/Cast Iron Fittings with Flexible Joint

2. REDUCER

刁士

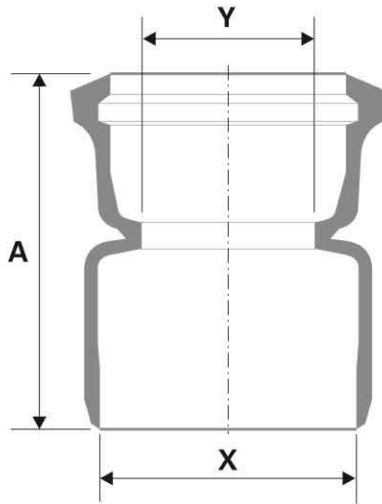

Code No. 貨號	Nominal Diameter 公稱內徑 (mm)	Dimension 尺寸 (mm)		
		A	X	Y
RK100075	100X075	195	100	75
RK150075	150X075	210	150	75
RK150100	150X100	210	150	100
RK200100	200X100	243	200	100
RK200150	200X150	250	200	150
RK225100	225X100	243	225	100
RK250150	225X150	250	225	150
RK300150	300X150	250	300	150
RK300225	300X225	260	300	225
*RK350150	350X150	250	350	150
*RK350300	350X300	265	350	300
*RK375300	375X300	265	375	300
*RK400250	400X250	262	400	250
*RK450150	450X150	250	450	150
*RK450300	450X300	265	450	300

\* Made to order

3. SOCKET

梳杰

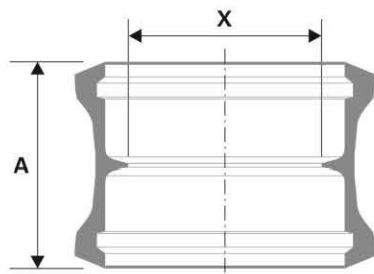

Code No. 貨號	Nominal Diameter 公稱內徑 (mm)	Dimension 尺寸 (mm)	
		A	X
RA075	75	150	75
RA100	100	165	100
RA150	150	165	150
RA200	200	206	200
RA225	225	208	225
RA250	250	215	250
RA300	300	215	300
* RA350	350	227	350
* RA375	375	231	375
* RA400	400	231	400
* RA450	450	235	450

\* Made to order

Note: All drawings are for reference only. (NOT TO SCALE)

Users must refer to individual products for actual design and dimension.

注意：以上圖表及尺寸，只供參考。所有尺寸、款式、規格均以實物為準。

All rights reserved. It is unlawful to copy or extract the whole or part of the materials from this catalog without the written consent of CHEUNG HING FOUNDRY (HK) LIMITED.

4. SHORT CONNECTING PIPE

有口短坭

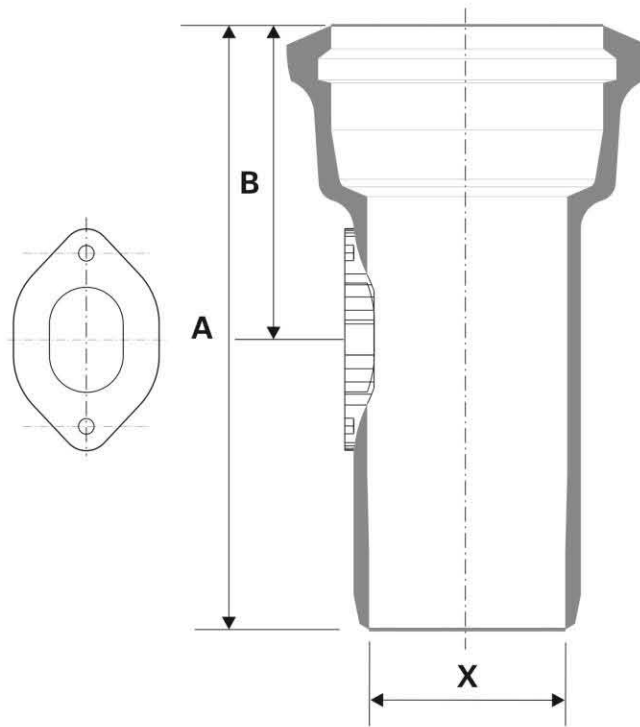

Code No. 貨號	Nominal Diameter 公稱內徑 (mm)	Dimension 尺寸 (mm)		
		A	B	X
RL075B	75	295	150	75
RL100B	100	310	160	100
RL150B	150	355	183	150
RL200B	200	450	205	200
RL225B	225	450	205	225
RL250B	250	450	205	250
RL300B	300	450	205	300
* RL350B	350	550	270	350
* RL375B	375	550	270	375
* RL400B	400	550	270	400
* RL450B	450	550	270	450

\* Made to order

Note: All drawings are for reference only. (NOT TO SCALE)

Users must refer to individual products for actual design and pattern.

注意：以上圖表及尺寸，只供參考。所有尺寸、款式、規格均以實物為準。

All rights reserved. It is unlawful to copy or extract the whole or part of the materials from this catalog without the written consent of CHEUNG HING FOUNDRY (HK) LIMITED.

5.1 TEE, 95°  
95° 三叉

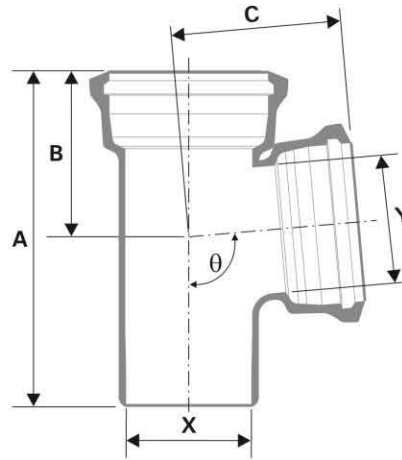

Code No. 貨號	Nominal Diameter 公稱內徑 (mm)	Dimension 尺寸 (mm)					
		A	B	C	X	Y	Θ
RH075075A	75X75	300	144	155	75	75	95°
RH100075A	100X75	320	149	167	100	75	95°
RH100100A	100X100	345	168	175	100	100	95°
RH150075A	150X75	360	188	193	150	75	95°
RH150100A	150X100	360	188	201	150	100	95°
RH150150A	150X150	405	200	205	150	150	95°
RH200100A	200X100	450	215	228	200	100	95°
RH200150A	200X150	450	215	232	200	150	95°
RH200200A	200X200	500	235	237	200	200	95°
RH225075A	225X75	450	225	232	225	75	95°
RH225100A	225X100	450	225	240	225	100	95°
RH225150A	225X150	450	225	245	225	150	95°
RH225225A	225X225	525	250	255	225	225	95°
RH250100A	250X100	450	217	254	250	100	95°
RH250150A	250X150	450	217	258	250	150	95°
RH250200A	250X200	525	257	271	250	200	95°
RH300100A	300X100	450	233	280	300	100	95°
RH300150A	300X150	450	233	285	300	150	95°
RH300200A	300X200	525	265	290	300	200	95°
RH300225A	300X225	525	256	288	300	225	95°
RH300300A	300X300	600	302	306	300	300	95°
* RH350100A	350X100	550	278	306	350	100	95°
* RH350150A	350X150	550	282	321	350	150	95°
* RH350200A	350X200	580	294	327	350	200	95°
* RH350350A	350X350	730	360	357	350	350	95°
* RH375100A	375X100	550	279	318	375	100	95°
* RH375150A	375X150	550	284	333	375	150	95°
* RH375225A	375X225	580	304	341	375	225	95°
* RH375250A	375X250	580	309	347	375	250	95°
* RH375300A	375X300	680	337	352	375	300	95°
* RH375375A	375X375	730	376	376	375	375	95°
* RH450225A	450X225	580	307	380	450	225	95°

Tees with access door are available upon request.

\* Made to order

Note: All drawings are for reference only. (NOT TO SCALE)

Users must refer to individual products for actual design and dimension.

注意：以上圖表及尺寸，只供參考。所有尺寸、款式、規格均以實物為準。

All rights reserved. It is unlawful to copy or extract the whole or part of the materials from this catalog without the written consent of CHEUNG HING FOUNDRY (HK) LIMITED.

5.2 TEE, 45°  
45° 斜上三叉

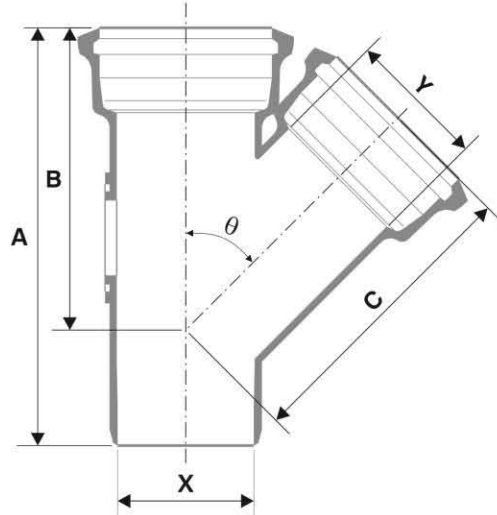

Code No. 貨號	Nominal Diameter 公稱內徑 (mm)	Dimension 尺寸 (mm)					
		A	B	C	X	Y	θ
RJ100100B	100X100	377	262	262	100	100	45°
RJ150100B	150X100	405	297	302	150	100	45°
RJ150150B	150X150	465	335	335	150	150	45°
RJ200150B	200X150	520	386	372	200	150	45°
RJ200200B	200X200	600	413	413	200	200	45°
RJ225100B	225X100	450	344	357	225	100	45°
RJ225150B	225X150	520	380	390	225	150	45°
RJ250150B	250X150	520	412	409	250	150	45°
RJ250200B	250X200	620	450	458	250	200	45°
RJ300100B	300X100	450	400	414	300	100	45°
RJ300150B	300X150	520	426	443	300	150	45°
RJ300200B	300X200	620	482	494	300	200	45°
RJ300300B	300X300	730	536	536	300	300	45°
*RJ350200B	350X200	700	544	567	350	200	45°
*RJ350250B	350X250	850	605	580	350	250	45°
*RJ400100B	400X100	550	502	500	400	100	45°
*RJ400300B	400X300	850	647	652	400	300	45°
*RJ450150B	450X150	550	533	564	450	150	45°
*RJ450300B	450X300	850	663	689	450	300	45°

\* Made to order

Note: All drawings are for reference only. (NOT TO SCALE)

Users must refer to individual products for actual design and pattern.

注意：以上圖表及尺寸，只供參考。所有尺寸、款式、規格均以實物為準。

All rights reserved. It is unlawful to copy or extract the whole or part of the materials from this catalog without the written consent of CHEUNG HING FOUNDRY (HK) LIMITED.

6. TRAP, HIGH INVERT “ P ”

深水 “ P ” 隔氣

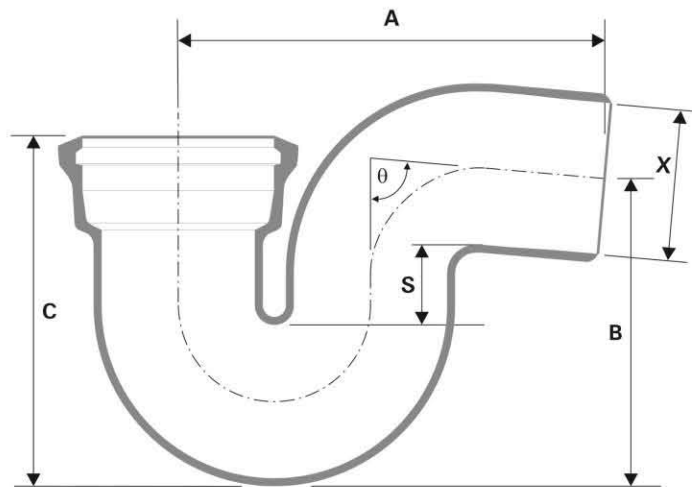

Code No. 貨號	Nominal Diameter 公稱內徑 (mm)	Dimension 尺寸 (mm)					
		A	B	C	S	X	θ
RG075A	75	260	204	272	80	75	85°
RG100A	100	335	232	295	80	100	85°
RG150A	150	420	310	350	80	150	85°
RG200A	200	530	388	406	80	200	85°
RG225A	225	560	425	445	80	225	85°
RG250A	250	620	476	470	90	250	85°
RG300A	300	680	546	527	90	300	85°
*RG375A	375	865	620	650	90	375	85°
*RG450A	450	995	766	710	95	450	85°

\* Made to order

Note: All drawings are for reference only. (NOT TO SCALE)

Users must refer to individual products for actual design and dimension.

注意：以上圖表及尺寸，只供參考。所有尺寸、款式、規格均以實物為準。

All rights reserved. It is unlawful to copy or extract the whole or part of the materials from this catalog without the written consent of CHEUNG HING FOUNDRY (HK) LIMITED.

**佳力高試驗中心有限公司**  
**CASTCO TESTING CENTRE LTD.**

香港新界粉嶺安樂村安全街29A號 29A, On Chuen Street, On Lok Tsuen, Fanling, N.T., Hong Kong.  
Tel: 2677 2032, 2677 2138 Fax: 2677 0351 E-mail: castco@netvigator.com Website: www.castco.com.hk

**CASTCO TESTING CENTRE LTD.**

**Test Certificate**  
**Dimension and Mass Check on Cast Iron Spigot and Socket Drain Pipes and Fittings**  
(Based on BS437: 1978 Clause 5)

Date of issue: 15-12-2004  
Page 1A of 1 page(s) Castco LRN: DP241113-1405 DIM

Details as supplied by client  
Client: Cheung Hing Foundry Limited Client's ref. no.: --  
Contract no.: -- Job title: --  
Sample description: 100 BS437 Socket with flexible joint.  
Manufacturer: Cheung Hing Foundry Limited Brand: CHF (Diamond)  
Remark: Sample Submitted by: Asia Development (1950) Ltd.

Laboratory test result  
Date sample received: 13-11-2004 Date of test: 13-11-2004

Dimension Check  
Specimen no.: DP241113-1405

Dimensions	BS requirement from figure 1	Product requirement from code no. RA100	Measured mean value
A	--	150mm	152.0mm
X	(min) ≥ 99mm	105mm	105.5mm
<p>Remarks: 1. Test result relates only to the specimen tested. 2. This report supersedes previous test certificate of Castco LRN:DP241113-1405DIM.</p>			

Checked by: W. K. LEUNG Approved signatory: PETER K. F. CHOI  
B.Sc., C. Eng., MICE, MHKIE  
Registered Professional Engineer

From No. PPE 020407, 29 of 40 (2004)

Hong Kong Accreditation Service (HKAS) has accredited this laboratory under the Hong Kong Laboratory Accreditation Scheme (HOKLAS) for specific laboratory activities as listed in the HOKLAS Directory of Accredited Laboratories. The results shown in this report were determined by this laboratory in accordance with its terms of accreditation. This report shall not be reproduced unless with prior written approval from this laboratory.

**佳力高試驗中心有限公司**  
**CASTCO TESTING CENTRE LTD.**

香港新界粉嶺安樂村安全街29A號 29A, On Chuen Street, On Lok Tsuen, Fanling, N.T., Hong Kong.  
Tel: 2677 2032, 2677 2138 Fax: 2677 0351 E-mail: castco@netvigator.com Website: www.castco.com.hk

**CASTCO TESTING CENTRE LTD.**

**Test Certificate**  
**Hydrostatic Test of Cast Iron Spigot and Socket Drain Pipes and Fittings**  
(BS437: 1978 Clause 7)

Date of issue: 15-12-2004  
Page 1A of 1 page Castco LRN: DP241113-1405 HYD

Details as supplied by client  
Client: Cheung Hing Foundry Limited Client's ref. no.: --  
Contract no.: -- Job title: --  
Description of pipe:  
Nominal bore: 100mm Length: -- Type: Socket with flexible joint  
Brand name: CHF (Diamond)

Delivery date: -- Manufacturer: Cheung Hing Foundry Limited Sample Submitted by: Asia Development (1950) Ltd.

Laboratory Test Result  
Date received: 13-11-2004 Date of test: 15-11-2004

Specimen no.	DP241113-1405
Actual internal hydrostatic pressure apply	170 kPa
Sustain period (min)	0.5
Test result	Passed

Remarks: 1. Test results relate only to the specimen tested.  
2. This report supersedes previous test certificate of Castco LRN:DP241113-1405HYD.

Checked by: W. K. Leung Certified by: PETER K. F. CHOI  
B.Sc., C. Eng., MICE, MHKIE  
Registered Professional Engineer

From No. PPE 020407, 29 of 40 (2004)

Hong Kong Accreditation Service (HKAS) has accredited this laboratory under the Hong Kong Laboratory Accreditation Scheme (HOKLAS) for specific laboratory activities as listed in the HOKLAS Directory of Accredited Laboratories. The results shown in this report were determined by this laboratory in accordance with its terms of accreditation. This report shall not be reproduced unless with prior written approval from this laboratory.

**佳力高試驗中心有限公司**  
**CASTCO TESTING CENTRE LTD.**

香港新界粉嶺安樂村安全街29A號 29A, On Chuen Street, On Lok Tsuen, Fanling, N.T., Hong Kong.  
Tel: 2677 2032, 2677 2138 Fax: 2677 0351 E-mail: castco@netvigator.com Website: www.castco.com.hk

**CASTCO TESTING CENTRE LTD.**

**Test Certificate**  
**Dimension and Mass Check on Cast Iron Spigot and Socket Drain Pipes and Fittings**  
(Based on BS437: 1978 Clause 5)

Date of issue: 15-12-2004  
Page 1A of 1 page(s) Castco LRN: DP241113-1419 DIM

Details as supplied by client  
Client: Cheung Hing Foundry Limited Client's ref. no.: --  
Contract no.: -- Job title: --  
Sample description: 150 x 95° BS437 Bend with flexible joint.  
Manufacturer: Cheung Hing Foundry Limited Brand: CHF (Diamond)  
Remark: Sample Submitted by: Asia Development (1950) Ltd.

Laboratory test result  
Date sample received: 13-11-2004 Date of test: 15-11-2004

Dimension Check  
Specimen no.: DP241113-1419

Dimensions	BS requirement from figure 1	Product requirement from code no. RC150A	Measured mean value
A	--	205mm	207.0mm
B	--	205mm	205.5mm
X	(min) ≥ 150mm	150mm	150.0mm
θ	--	95°	95°
<p>Remarks: 1. Test result relates only to the specimen tested. 2. This report supersedes previous test certificate of Castco LRN:DP241113-1419DIM.</p>			

Checked by: W. K. LEUNG Approved signatory: PETER K. F. CHOI  
B.Sc., C. Eng., MICE, MHKIE  
Registered Professional Engineer

From No. PPE 020407, 29 of 40 (2004)

Hong Kong Accreditation Service (HKAS) has accredited this laboratory under the Hong Kong Laboratory Accreditation Scheme (HOKLAS) for specific laboratory activities as listed in the HOKLAS Directory of Accredited Laboratories. The results shown in this report were determined by this laboratory in accordance with its terms of accreditation. This report shall not be reproduced unless with prior written approval from this laboratory.

**佳力高試驗中心有限公司**  
**CASTCO TESTING CENTRE LTD.**

香港新界粉嶺安樂村安全街29A號 29A, On Chuen Street, On Lok Tsuen, Fanling, N.T., Hong Kong.  
Tel: 2677 2032, 2677 2138 Fax: 2677 0351 E-mail: castco@netvigator.com Website: www.castco.com.hk

**CASTCO TESTING CENTRE LTD.**

**Test Certificate**  
**Hydrostatic Test of Cast Iron Spigot and Socket Drain Pipes and Fittings**  
(BS437: 1978 Clause 7)

Date of issue: 15-12-2004  
Page 1A of 1 page Castco LRN: DP241113-1419 HYD

Details as supplied by client  
Client: Cheung Hing Foundry Limited Client's ref. no.: --  
Contract no.: -- Job title: --  
Description of pipe:  
Nominal bore: 150mm Length: -- Type: 95° Bend with flexible joint  
Brand name: CHF (Diamond)

Delivery date: -- Manufacturer: Cheung Hing Foundry Limited Sample Submitted by: Asia Development (1950) Ltd.

Laboratory Test Result  
Date received: 13-11-2004 Date of test: 15-11-2004

Specimen no.	DP241113-1419
Actual internal hydrostatic pressure apply	170 kPa
Sustain period (min)	0.5
Test result	Passed

Remarks: 1. Test results relate only to the specimen tested.  
2. This report supersedes previous test certificate of Castco LRN:DP241113-1419HYD.

Checked by: W. K. Leung Certified by: PETER K. F. CHOI  
B.Sc., C. Eng., MICE, MHKIE  
Registered Professional Engineer

From No. PPE 020407, 29 of 40 (2004)

Hong Kong Accreditation Service (HKAS) has accredited this laboratory under the Hong Kong Laboratory Accreditation Scheme (HOKLAS) for specific laboratory activities as listed in the HOKLAS Directory of Accredited Laboratories. The results shown in this report were determined by this laboratory in accordance with its terms of accreditation. This report shall not be reproduced unless with prior written approval from this laboratory.



**佳力高試驗中心有限公司**  
**CASTCO TESTING CENTRE LTD.**

香港新界粉嶺安樂村安全街29A號 29A, On Chuen Street, On Lok Tsuen, Fanling, N.T., Hong Kong  
Tel: 2677 2032, 2677 2138 Fax: 2677 0351 E-mail: castco@netvigator.com Website: www.castco.com.hk

**Test Certificate**  
**Dimension and Mass Check on Cast Iron Spigot and Socket Drain Pipes and Fittings**  
(Based on BS437: 1978 Clause 5)

Date of issue: 15-12-2004 Page 1A of 1 page(s) Castco LRN: DP241113-1421 DIM

**Details as supplied by client**  
Client: Cheung Hing Foundry Limited Client's ref. no.: --  
Contract no.: -- Job title: --  
Sample description: 150 x 45° BS437 Bend with flexible joint.  
Manufacturer: Cheung Hing Foundry Limited Brand: **CHF** (Diamond)  
Remark: Sample Submitted by: Asia Development (1950) Ltd.

**Laboratory test result**  
Date sample received: 13-11-2004 Date of test: 15-11-2004

**Dimensions Check**  
Specimen no.: DP241113-1421

Dimensions	BS requirement from figure 1	Product requirement from code no. RB150A	Measured mean value
A	--	155mm	159.0mm
B	--	155mm	154.5mm
X (min) ≥ 150mm	--	150mm	150.0mm
θ	--	45°	45°

Remarks: 1. Test result relates only to the specimen tested.  
2. This report supersedes previous test certificate of Castco LRN:DP241113-1421DIM.

Checked by: W.K. LEUNG Approved signatory: **PETER K. F. CHOI**  
B.Sc., C. Eng., MICE, MHKIE  
Registered Professional Engineer

Hong Kong Accreditation Service (HKAS) has accredited this laboratory under the Hong Kong Laboratory Accreditation Scheme (HOKLAS) for specific laboratory activities as listed in the HOKLAS Directory of Accredited Laboratories. The results shown in this report were determined by this laboratory in accordance with its terms of accreditation. This report shall not be reproduced unless with prior written approval from this laboratory.

**佳力高試驗中心有限公司**  
**CASTCO TESTING CENTRE LTD.**

香港新界粉嶺安樂村安全街29A號 29A, On Chuen Street, On Lok Tsuen, Fanling, N.T., Hong Kong  
Tel: 2677 2032, 2677 2138 Fax: 2677 0351 E-mail: castco@netvigator.com Website: www.castco.com.hk

**Test Certificate**  
**Dimension and Mass Check on Cast Iron Spigot and Socket Drain Pipes and Fittings**  
(Based on BS437: 1978 Clause 5)

Date of issue: 15-12-2004 Page 1A of 1 page(s) Castco LRN: DP241113-1415 DIM

**Details as supplied by client**  
Client: Cheung Hing Foundry Limited Client's ref. no.: --  
Contract no.: -- Job title: --  
Sample description: 100 x 100 BS437 Tee with flexible joint.  
Manufacturer: Cheung Hing Foundry Limited Brand: **CHF** (Diamond)  
Remark: Sample Submitted by: Asia Development (1950) Ltd.

**Laboratory test result**  
Date sample received: 13-11-2004 Date of test: 15-11-2004

**Dimensions Check**  
Specimen no.: DP241113-1415

Dimensions	BS requirement from figure 1	Product requirement from code no. RH100100A	Measured mean value
A	--	345mm	343.5mm
B	--	168mm	172.0mm
C	--	174.5mm	175.0mm
X (min) ≥ 99mm	--	100mm	100.5mm
θ	--	95°	95°

Remarks: 1. Test result relates only to the specimen tested.  
2. This report supersedes previous test certificate of Castco LRN:DP241113-1415DIM.

Checked by: W.K. LEUNG Approved signatory: **PETER K. F. CHOI**  
B.Sc., C. Eng., MICE, MHKIE  
Registered Professional Engineer

Hong Kong Accreditation Service (HKAS) has accredited this laboratory under the Hong Kong Laboratory Accreditation Scheme (HOKLAS) for specific laboratory activities as listed in the HOKLAS Directory of Accredited Laboratories. The results shown in this report were determined by this laboratory in accordance with its terms of accreditation. This report shall not be reproduced unless with prior written approval from this laboratory.

**佳力高試驗中心有限公司**  
**CASTCO TESTING CENTRE LTD.**

香港新界粉嶺安樂村安全街29A號 29A, On Chuen Street, On Lok Tsuen, Fanling, N.T., Hong Kong  
Tel: 2677 2032, 2677 2138 Fax: 2677 0351 E-mail: castco@netvigator.com Website: www.castco.com.hk

**Test Certificate**  
**Dimension and Mass Check on Cast Iron Spigot and Socket Drain Pipes and Fittings**  
(Based on BS437: 1978 Clause 5)

Date of issue: 15-12-2004 Page 1A of 1 page(s) Castco LRN: DP241113-1411 DIM

**Details as supplied by client**  
Client: Cheung Hing Foundry Limited Client's ref. no.: --  
Contract no.: -- Job title: --  
Sample description: 100 x 300R BS437 Large Radius Bend with flexible joint.  
Manufacturer: Cheung Hing Foundry Limited Brand: **CHF** (Diamond)  
Remark: Sample Submitted by: Asia Development (1950) Ltd.

**Laboratory test result**  
Date sample received: 13-11-2004 Date of test: 17-11-2004

**Dimensions Check**  
Specimen no.: DP241113-1411

Dimensions	BS requirement from figure 1	Product requirement from code no. RD100A	Measured mean value
A	--	390mm	393.5mm
B	--	370mm	371.0mm
X (min) ≥ 99mm	--	100mm	100.5mm
θ	--	95°	95.5°
R	--	300mm	300.5mm

Remarks: 1. Test result relates only to the specimen tested.  
2. This report supersedes previous test certificate of Castco LRN:DP241113-1411DIM.

Checked by: W.K. LEUNG Approved signatory: **PETER K. F. CHOI**  
B.Sc., C. Eng., MICE, MHKIE  
Registered Professional Engineer

Hong Kong Accreditation Service (HKAS) has accredited this laboratory under the Hong Kong Laboratory Accreditation Scheme (HOKLAS) for specific laboratory activities as listed in the HOKLAS Directory of Accredited Laboratories. The results shown in this report were determined by this laboratory in accordance with its terms of accreditation. This report shall not be reproduced unless with prior written approval from this laboratory.

**佳力高試驗中心有限公司**  
**CASTCO TESTING CENTRE LTD.**

香港新界粉嶺安樂村安全街29A號 29A, On Chuen Street, On Lok Tsuen, Fanling, N.T., Hong Kong  
Tel: 2677 2032, 2677 2138 Fax: 2677 0351 E-mail: castco@netvigator.com Website: www.castco.com.hk

**Test Certificate**  
**Dimension and Mass Check on Cast Iron Spigot and Socket Drain Pipes and Fittings**  
(Based on BS437: 1978 Clause 5)

Date of issue: 15-12-2004 Page 1A of 1 page(s) Castco LRN: DP241113-1425 DIM

**Details as supplied by client**  
Client: Cheung Hing Foundry Limited Client's ref. no.: --  
Contract no.: -- Job title: --  
Sample description: 150 BS437 High Invert P Trap with flexible joint.  
Manufacturer: Cheung Hing Foundry Limited Brand: **CHF** (Diamond)  
Remark: Sample Submitted by: Asia Development (1950) Ltd.

**Laboratory test result**  
Date sample received: 13-11-2004 Date of test: 22-11-2004

**Dimensions Check**  
Specimen no.: DP241113-1425

Dimensions	BS requirement from figure 1	Product requirement from code no. RG150A	Measured mean value
A	--	420mm	424.0mm
B	--	310mm	311.5mm
C	--	350mm	354.5mm
S	--	80mm	86.0mm
X (min) ≥ 150mm	--	150mm	151.5mm
θ	--	95°	94.5°

Remarks: 1. Test result relates only to the specimen tested.  
2. This report supersedes previous test certificate of Castco LRN:DP241113-1425DIM.

Checked by: W.K. LEUNG Approved signatory: **PETER K. F. CHOI**  
B.Sc., C. Eng., MICE, MHKIE  
Registered Professional Engineer

Hong Kong Accreditation Service (HKAS) has accredited this laboratory under the Hong Kong Laboratory Accreditation Scheme (HOKLAS) for specific laboratory activities as listed in the HOKLAS Directory of Accredited Laboratories. The results shown in this report were determined by this laboratory in accordance with its terms of accreditation. This report shall not be reproduced unless with prior written approval from this laboratory.

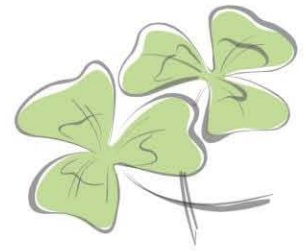

Please Preserve Our Environment  
by using Cast Iron Products

保護環境  
使用環保鑄鐵產品

*All rights reserved. It is unlawful to copy or extract the whole or part of the from this catalog without the written consent of Cheung Hing Foundry (HK) Limited. Users must follow the installing instructions laid. All castings should benefit from proper, regular operation and maintenance. Drawings are for reference only.*



**CHEUNG HING FOUNDRY (HK) LIMITED**  
Address : 299, Pak Sha Tsuen,  
Kung Um Road, Yuen Long, Hong Kong  
Tel : ( 852 ) 2447-1262 Fax : ( 852 ) 2447-0198

**祥興鑄鐵有限公司**  
地址：香港 元朗公庵路白沙村 299 號  
Email : chf@chfhk.com <http://www.chfhk.com>