



Eco-Fittings For

BS437 Cast Iron Spigot & Socket Drain Pipes &
BS4622 Grey Iron Pipes

Nominal Bore: 75-700mm



祥興鑄鐵有限公司
CHEUNG HING FOUNDRY (HK) LIMITED

CONTENTS



 Introduction	簡介	P.1
1. Bend	彎邊	
1.1 Bend, 95°	彎邊, 95°	P.2
1.2 Bend, 45°	彎邊, 45°	P.3
1.3 Bend, Large Radius, 300R & 400R	彎邊, 300R & 400R	P.4
2. Reducer	刁士	P.5
3. Socket	梳杰	P.6
4. Tee	三叉	
4.1 Tee, Equal, 95°	三叉, 等徑, 95°	P.7
4.2 Tee, Equal, 45°	三叉, 等徑, 45°	P.8
5. Trap	隔氣	
5.1 Trap, High Invert " P "	深水 "P" 隔氣	P.9
5.2 Trap, Disconnecting	狗頭 隔氣	P.10



Guidance Notes on Buildings Department PNAP 282

P.11



HOKLAS Endorsed Test Certificates

P.12~P.13

Environmental Friendly Cast Iron Products



香港商標註冊號：1991年第2781號
中華人民共和國商標註冊証第870501號



香港商標註冊號：1993年第5681號
中華人民共和國商標註冊証第136742號



祥興鑄鐵有限公司
CHEUNG HING FOUNDRY (HK) LIMITED

Introduction

CHF- has made every endeavour to develop and manufacture its products to meet with the requirement of relevant standards and to cater for the needs of local and overseas drainage and plumbing industries.

CHF specializes in manufacturing cast iron pipes and fittings, rainwater outlets, manhole covers and frames, channel gratings and other special castings such as aluminium, copper, stainless steel, etc.

The purpose of this catalog is to provide a comprehensive range of CHF cast iron fittings, which are compatible with BS 437 Cast iron spigot & socket drain pipes and BS4622 Grey iron pipes.

Material : The BS 437 & BS 4622 to fittings of cast iron comply with BS EN 1561:1997, EN-GJL-150.

For further information, feel free to contact us at
telephone no. (852) 2447-1262 and fax no. (852) 2447-0198.
Email : chf@chfhk.com

Note: According to BS437:1978, there is a permissible deviation of $\pm 12.5\text{mm}$ on the length of all pipes and fittings.

CHF Preserves the Environment by RECYCLING



祥興鑄鐵有限公司
CHEUNG HING FOUNDRY (HK) LIMITED

Fittings For

BS437 Cast Iron spigot & socket drain pipes and BS4622 Grey Iron pipes

BEND

1.1 BEND, 95° 彎邊, 95°

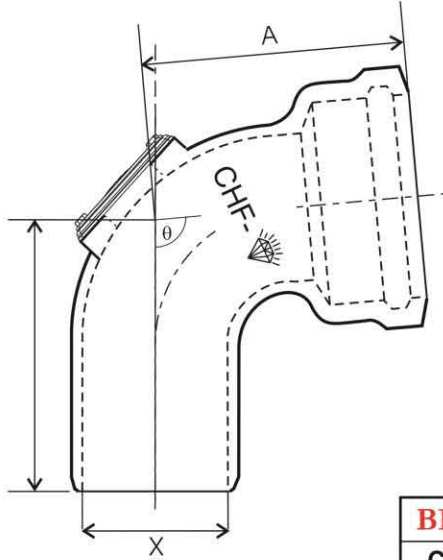

BEND, 95° 彎邊, 95°

Code No. 貨號	Nominal Bore 公稱內徑 (mm)	Dimension 尺寸 (mm)			
		A	B	X	θ
BBD075B	75	155	155	75	95°
BBD100B	100	175	175	100	95°
BBD150B	150	205	205	150	95°
* BBD200B	200	240	260	200	95°
BBD225B	225	250	250	225	95°
* BBD250B	250	285	285	250	95°
* BBD300B	300	310	300	300	95°
* BBD350B	350	357	357	350	95°
* BBD375B	375	376	376	375	95°
* BBD400B	400	390	390	400	95°
* BBD450B	450	415	415	450	95°
* BBD500B	500	440	440	500	95°
* BBD600B	600	510	510	600	95°
* BBD700B	700	570	570	700	95°

* Custom-Made Non-Standard Castings

All drawings and dimensions are for reference only (not to scale). Users must refer to the individual product for actual design and pattern.

Fittings For

BS437 Cast Iron spigot & socket drain pipes and BS4622 Grey Iron pipes

BEND

1.2 BEND, 45° 彎邊, 45°

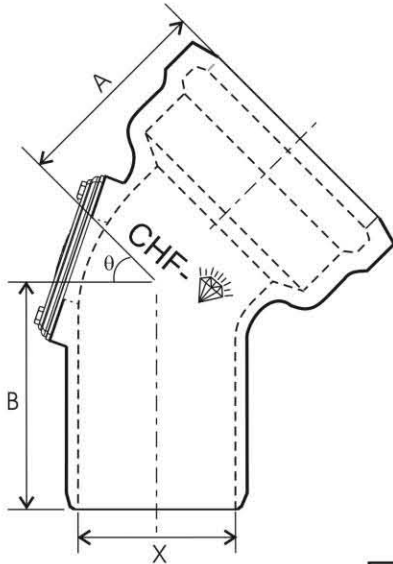

BEND, 45° 彎邊, 45°					
Code No. 貨號	Nominal Bore 公稱內徑 (mm)	Dimension 尺寸 (mm)			
		A	B	X	θ
BAD075B	75	130	140	75	45°
BAD100B	100	140	140	100	45°
BAD150B	150	155	155	150	45°
* BAD200B	200	175	195	200	45°
BAD225B	225	180	180	225	45°
* BAD250B	250	200	200	250	45°
* BAD300B	300	206	206	300	45°
* BAD350B	350	237	237	350	45°
* BAD375B	375	250	250	375	45°
* BAD400B	400	257	257	400	45°
* BAD450B	450	270	270	450	45°
* BAD500B	500	280	280	500	45°
* BAD600B	600	325	325	600	45°

* Custom-Made Non-Standard Castings

All drawings and dimensions are for reference only (not to scale). Users must refer to the individual product for actual design and pattern.

BEND

1.3 BEND, LARGE RADIUS, 300R & 400R 彎邊, 300R & 400R

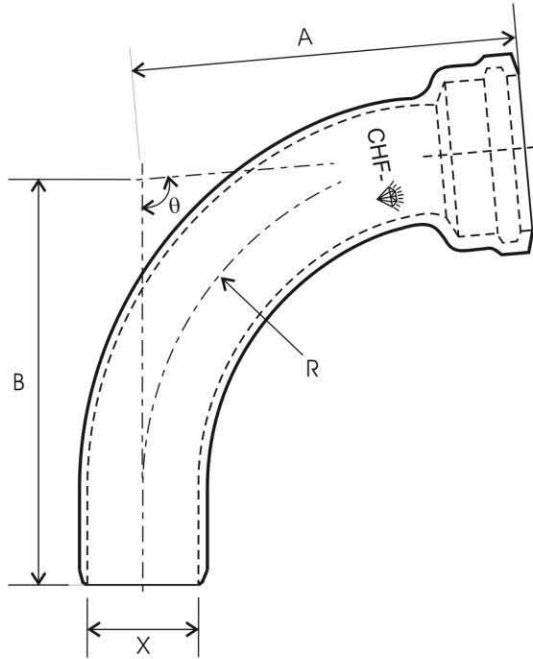

BEND, LARGE RADIUS, 300R & 400R
彎邊, 300R & 400R

Code No. 貨號	Nominal Bore 公稱內徑 (mm)	Dimension 尺寸 (mm)				
		A	B	X	R	θ
BDD100A	100	380	370	100	300	95°
BDD150A	150	386	365	150	300	95°
* BDD200A	200	485	475	200	400	95°
BDD225A	225	485	475	225	400	95°
* BDD250A	250	490	480	250	400	95°
* BDD300A	300	490	480	300	400	95°

* Custom-Made Non-Standard Castings

All drawings and dimensions are for reference only (not to scale). Users must refer to the individual product for actual design and pattern.



Fittings For

**BS437 Cast Iron spigot & socket drain pipes and
BS4622 Grey Iron pipes**

REDUCER

2. REDUCER 刁士

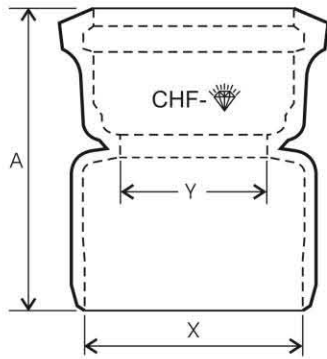

REDUCER 刁士				
Code No. 貨號	Nominal Bore 公稱內徑 (mm)	Dimension 尺寸 (mm)		
		A	X	Y
FAD075050	75 X 50	185	50	50
FAD100075	100 X 75	220	100	75
FAD150100	150 X 100	210	150	100
* FAD200150	200 X 150	230	200	150
FAD225150	225 X 150	240	225	150
* FAD250200	250 X 200	240	250	225
* FAD300250	300 X 250	263	300	250
* FAD350300	350 X 300	248	350	300
* FAD375350	375 X 350	255	375	350
* FAD400375	400 X 375	260	400	375
* FAD450400	450 X 400	257	450	400
* FAD500450	500 X 450	277	500	450
* FAD600500	600 X 500	282	600	500

* Custom-Made Non-Standard Castings

All drawings and dimensions are for reference only (not to scale). Users must refer to the individual product for actual design and pattern.



祥興鑄鐵有限公司
CHEUNG HING FOUNDRY (HK) LIMITED



Fittings For

BS437 Cast Iron spigot & socket drain pipes and BS4622 Grey Iron pipes

SOCKET

3. SOCKET 梳杰

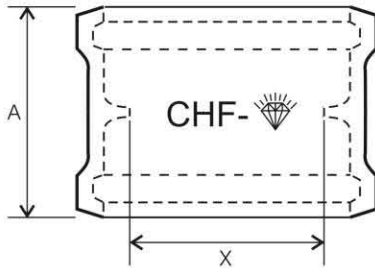

SOCKET 梳杰			
Code No. 貨號	Nominal Bore 公稱內徑 (mm)	Dimension 尺寸 (mm)	
		A	X*
KAD075	75	150	78
KAD100	100	150	105
KAD150	150	165	153
* KAD200	200	206	204
KAD225	225	208	230
* KAD250	250	215	256
* KAD300	300	215	305
* KAD350	350	227	355
* KAD375	375	231	378
* KAD400	400	231	405
* KAD450	450	235	455
* KAD500	500	239	509
* KAD600	600	250	607
* KAD700	700	260	705

* Dimensions X are custom-designed for functional purpose.
* Custom-Made Non-Standard Castings

All drawings and dimensions are for reference only (not to scale). Users must refer to the individual product for actual design and pattern.





Fittings For

BS437 Cast Iron spigot & socket drain pipes and BS4622 Grey Iron pipes

TEE

4.1 TEE, EQUAL, 95° 三叉, 等徑, 95°

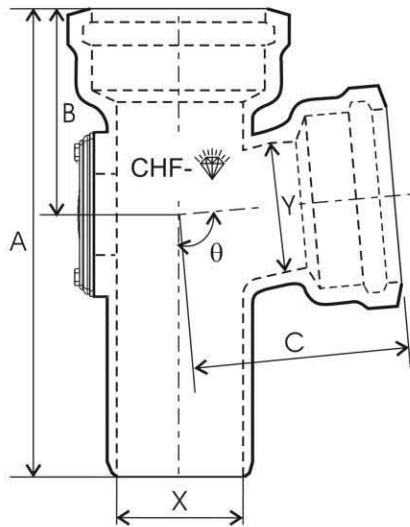

TEE, EQUAL, 95° 三叉, 等徑, 95°							
Code No. 貨號	Nominal Bore 公稱內徑 (mm)	Dimension 尺寸 (mm)					
		A	B	C	X	Y	θ
TAD075075B	75 X 75	300	144	150	75	75	95°
TAD100100B	100 X 100	345	168	175	100	100	95°
TAD150150B	150 X 150	405	200	205	150	150	95°
* TAD200200B	200 X 200	500	235	237	200	200	95°
TAD225225B	225 X 225	525	250	255	225	225	95°
* TAD250250B	250 X 250	560	280	285	250	250	95°
* TAD300300B	300 X 300	600	302	306	300	300	95°
* TAD350350B	350 X 350	730	360	357	350	350	95°
* TAD375375B	375 X 375	730	376	376	375	375	95°
* TAD400400B	400 X 400	790	390	389	400	400	95°
* TAD450450B	450 X 450	850	430	430	450	450	95°
* TAD500500B	500 X 500	960	487	453	500	500	95°

* Custom-Made Non-Standard Castings

All drawings and dimensions are for reference only (not to scale). Users must refer to the individual product for actual design and pattern.



祥興鑄鐵有限公司
CHEUNG HING FOUNDRY (HK) LIMITED

Fittings For

BS437 Cast Iron spigot & socket drain pipes and BS4622 Grey Iron pipes

TEE

4.2 TEE, EQUAL, 45° 三叉, 等徑, 45°

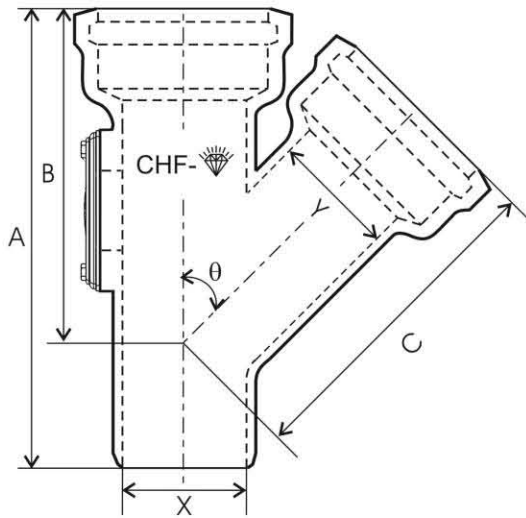

TEE, EQUAL, 45° 三叉, 等徑, 45°							
Code No. 貨號	Nominal Bore 公稱內徑 (mm)	Dimension 尺寸 (mm)					
		A	B	C	X	Y	θ
TBD075075B	75 X 75	338	229	229	75	75	45°
TBD100100B	100 X 100	377	262	262	100	100	45°
TBD150150B	150 X 150	465	337	337	150	150	45°
* TBD200200B	200 X 200	600	415	415	200	200	45°
TBD225225B	225 X 225	620	438	438	225	225	45°
* TBD250250B	250 X 250	650	470	470	250	250	45°
* TBD300300B	300 X 300	730	537	537	300	300	45°
* TBD350350B	350 X 350	960	640	640	350	350	45°
* TBD375375B	375 X 375	960	674	674	375	375	45°
* TBD400400B	400 X 400	960	700	700	400	400	45°
* TBD450450B	450 X 450	1060	780	780	450	450	45°
* TBD500500B	500 X 500	1200	875	875	500	500	45°

* Custom-Made Non-Standard Castings

All drawings and dimensions are for reference only (not to scale). Users must refer to the individual product for actual design and pattern.

Fittings For

BS437 Cast Iron spigot & socket drain pipes and BS4622 Grey Iron pipes

TRAP Custom-Made Non-Standard Castings

5.1 **TRAP, HIGH INVERT "P"**
深水"P"隔氣

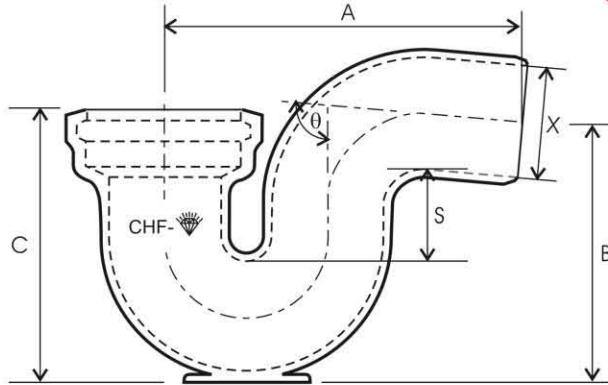

TRAP, HIGH INVERT "P"
深水"P"隔氣

Code No. 貨號	Nominal Bore 公稱內徑 (mm)	Dimension 尺寸 (mm)					
		A	B	C	S	X	θ
CBD75A	75	260	204	272	80	75	95°
CBD100A	100	335	232	295	80	100	95°
CBD150A	150	420	310	350	80	150	95°
* CBD200A	200	530	388	406	80	200	95°
CBD225A	225	560	425	445	80	225	95°
* CBD250A	250	620	475	468	90	250	95°
* CBD300A	300	680	546	527	90	300	95°
* CBD350A	350	800	627	587	90	350	95°
* CBD375A	375	840	667	617	95	375	95°
* CBD400A	400	875	708	649	95	400	95°
* CBD450A	450	970	782	700	95	450	95°
* CBD500A	500	1030	863	754	100	500	95°
* CBD600A	600	1220	1012	865	100	600	95°

* Custom-Made Non-Standard Castings

All drawings and dimensions are for reference only (not to scale). Users must refer to the individual product for actual design and pattern.



Fittings For

BS437 Cast Iron spigot & socket drain pipes and BS4622 Grey Iron pipes

TRAP Custom-Made Non-Standard Castings

5.2 TRAP, DISCONNECTING 狗頭隔氣

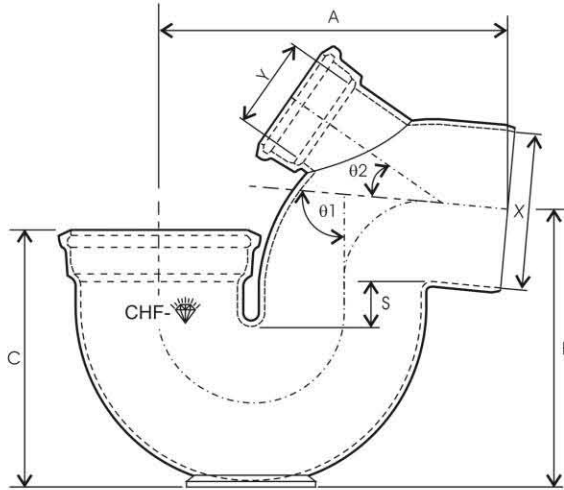

For CED150-CED600

TRAP, DISCONNECTING 狗頭隔氣									
Code No. 貨號	Nominal Bore 公稱內徑 (mm)	Dimension 尺寸 (mm)							
		A	B	C	S	X	Y	θ1	θ2
CED100	100 X 75	380	240	245	80	100	75	95°	35°
CED150	150 X 100	420	310	290	80	150	100	95°	35°
CED200	200 X 150	530	388	406	80	200	150	95°	35°
CED225	225 X 150	560	425	406	80	225	150	95°	35°
* CED250	250 X 150	620	475	445	80	250	150	95°	35°
* CED300	300 X 150	715	545	480	80	300	150	95°	35°
* CED350	350 X 150	800	627	587	80	350	150	95°	35°
* CED375	375 X 225	840	667	617	80	375	225	95°	35°
* CED400	400 X 225	875	708	649	80	400	225	95°	35°
* CED450	450 X 225	970	782	700	80	450	225	95°	35°
* CED500	500 X 225	1030	983	754	100	500	225	95°	35°
* CED600	600 X 225	1220	1012	865	100	600	225	95°	35°

* Custom-Made Non-Standard Castings

All drawings and dimensions are for reference only (not to scale). Users must refer to the individual product for actual design and pattern.



祥興鑄鐵有限公司
CHEUNG HING FOUNDRY (HK) LIMITED



Guidance Notes on Buildings Department PNAP 282

Identification and Testing of Drainage Products

Buildings Department requires the manufacturer of drainage products to fulfill the testing of the Brand for identification of the compliance of products to relevant standards. The Hong Kong Laboratory Accreditation Scheme (HOKLAS) endorsed test report shall clearly specify the Brand of the drainage products.

Verification of Compliance of Drainage Products

The Authorised Person and the Registered Contractor responsible for a particular project shall ensure that the pipe body, fitting and accessory of the same Brand specified in the endorsed test reports are to be used in the project. This is not uncommon to find faked drainage products available in the market.

HOKLAS Endorsed Test Certificates

CHF has successfully obtained a comprehensive set of HOKLAS endorsed test certificates for its cast iron pipes and fittings for drainage works. These test certificates are issued by the laboratory accredited by the Hong Kong Accreditation Service (HKAS) of the HKSAR Government.



CASTCO 佳力高試驗中心有限公司
CASTCO TESTING CENTRE LTD.

香港新界荃灣白雲街12-14號 2/F, On Cheung Street, On Lok Tsuen, Tseung Kwei Tung, Hong Kong
Tel: 2677 2032, 2677 2138 Fax: 2677 0911 E-mail: castco@hoklas.com Website: www.castco.com.hk

Test Certificate
Dimension and Mass Check on Cast Iron Spigot and Socket Drain Pipes and Fittings
(Based on BS47: 1978 Clause 5)

Date of issue: 06-03-2005
Page 1A of 1 page(s) Castco LBN: DP251007-0413 DIM

Details as supplied by client
Client: Cheung Hing Foundry Limited Client's ref. no.: --
Contract no.: -- Job title: --
Sample description: 300mm x 93° Boral with Access Door
Manufacturer: Cheung Hing Foundry Limited Brand: CHF
Remark: Sample Submitted by: Asia Development (HK) Ltd

Laboratory test result
Date sample received: 07-10-2005 Date of test: 27-10-2005

Dimension Check
Specimen no.: DP251007-0413

Dimensions	Product requirement Item code no. (BS47:1978)	Measured mean value
A	210mm	210.0mm
B	300mm	300.0mm
E	405mm	404.0mm
J	103mm	103.0mm
K	300mm	299.0mm
X1	344mm	343.0mm
B	93°	93°

Remarks: 1. Test result relates only to the specimen tested.
2. This report supersedes previous test certificate of Castco LBN: DP251007-0413 DIM.

Checked by: W.K. LEEING Approved signature: K. YEO
K. YEO Technical Manager

Hong Kong Accreditation Scheme (HKAS) has accredited this laboratory under the Hong Kong Laboratory Accreditation Scheme (HKLAS) for specific laboratory activities as listed in the HOKLAS Directory of Accredited Laboratories. The results shown in this report were generated by this laboratory in accordance with its terms of accreditation. This report shall not be reproduced without your written approval from this laboratory.

CASTCO 佳力高試驗中心有限公司
CASTCO TESTING CENTRE LTD.

香港新界荃灣白雲街12-14號 2/F, On Cheung Street, On Lok Tsuen, Tseung Kwei Tung, Hong Kong
Tel: 2677 2032, 2677 2138 Fax: 2677 0911 E-mail: castco@hoklas.com Website: www.castco.com.hk

Test Certificate
Hydrostatic Test of Cast Iron Spigot and Socket Drain Pipes and Fittings
(BS47: 1978 Clause 7)

Date of issue: 06-03-2005
Page 1A of 1 page(s) Castco LBN: DP251007-0413 HYD

Details as supplied by client
Sample Submitted by: Asia Development (HK) Ltd
Client: Cheung Hing Foundry Limited Client's ref. no.: --
Contract no.: -- Job title: --

Description of pipe:
Nominal bore: 300mm Length: -- Type: 93° Bend with Access Door
Brand name: --

Delivery date: --

Laboratory Test Result
Date received: 07-10-2005 Date of test: 14-10-2005

Specimen no.	DP251007-0413
Actual internal hydrostatic pressure apply	170 kPa
Sustain period (min)	0.5
Test result	Passed

Remarks: 1. Test results relate only to the specimen tested.
2. This report supersedes previous test certificate of Castco LBN: DP251007-0413 HYD.

Checked by: W.K. LEEING Certified by: K. YEO
K. YEO Technical Manager

Hong Kong Accreditation Scheme (HKAS) has accredited this laboratory under the Hong Kong Laboratory Accreditation Scheme (HKLAS) for specific laboratory activities as listed in the HOKLAS Directory of Accredited Laboratories. The results shown in this report were generated by this laboratory in accordance with its terms of accreditation. This report shall not be reproduced without your written approval from this laboratory.

CASTCO 佳力高試驗中心有限公司
CASTCO TESTING CENTRE LTD.

香港新界荃灣白雲街12-14號 2/F, On Cheung Street, On Lok Tsuen, Tseung Kwei Tung, Hong Kong
Tel: 2677 2032, 2677 2138 Fax: 2677 0911 E-mail: castco@hoklas.com Website: www.castco.com.hk

Test Certificate
Dimension and Mass Check on Cast Iron Spigot and Socket Drain Pipes and Fittings
(Based on BS47: 1978 Clause 5)

Date of issue: 01-12-2005
Page 1A of 1 page(s) Castco LBN: DP250826-0311 DIM

Details as supplied by client
Client: Cheung Hing Foundry Limited Client's ref. no.: --
Contract no.: -- Job title: --
Sample description: 300mm Socket
Manufacturer: Cheung Hing Foundry Limited Brand: CHF
Remark: Sample Submitted by: Asia Development (HK) Ltd

Laboratory test result
Date sample received: 28-08-2005 Date of test: 24-09-2005

Dimension Check
Specimen no.: DP250826-0311

Dimensions	Product requirement Item code no. (BS47:1978)	Measured mean value
A	210mm	215.0mm
B	405mm	405.0mm
X	305mm	305.0mm
X1	344mm	344.0mm

Remarks: 1. Test result relates only to the specimen tested.
2. This report supersedes previous test certificate of Castco LBN: DP250826-0311 DIM.

Checked by: W.K. LEEING Approved signature: W.K. LEE
W.K. LEE
B.Sc., Eng., M.C.P., M.H.K.E.
Registered Professional Engineer
General Manager

Hong Kong Accreditation Scheme (HKAS) has accredited this laboratory under the Hong Kong Laboratory Accreditation Scheme (HKLAS) for specific laboratory activities as listed in the HOKLAS Directory of Accredited Laboratories. The results shown in this report were generated by this laboratory in accordance with its terms of accreditation. This report shall not be reproduced without your written approval from this laboratory.

CASTCO 佳力高試驗中心有限公司
CASTCO TESTING CENTRE LTD.

香港新界荃灣白雲街12-14號 2/F, On Cheung Street, On Lok Tsuen, Tseung Kwei Tung, Hong Kong
Tel: 2677 2032, 2677 2138 Fax: 2677 0911 E-mail: castco@hoklas.com Website: www.castco.com.hk

Test Certificate
Hydrostatic Test of Cast Iron Spigot and Socket Drain Pipes and Fittings
(BS47: 1978 Clause 7)

Date of issue: 12-10-2005
Page 1 of 1 page(s) Castco LBN: DP250826-0311 HYD

Details as supplied by client
Sample Submitted by: Asia Development (HK) Ltd
Client: Cheung Hing Foundry Limited Client's ref. no.: --
Contract no.: -- Job title: --

Description of pipe:
Nominal bore: 300mm Length: -- Type: Socket
Brand name: CHF

Delivery date: --

Laboratory Test Result
Date received: 28-08-2005 Date of test: 20-09-2005

Specimen no.	DP250826-0311
Actual internal hydrostatic pressure apply	170 kPa
Sustain period (min)	0.5
Test result	Passed

Remarks: 1. Test results relate only to the specimen tested.

Checked by: W.K. LEEING Certified by: W.K. LEE
W.K. LEE
B.Sc., Eng., M.C.P., M.H.K.E.
Registered Professional Engineer
General Manager

Hong Kong Accreditation Scheme (HKAS) has accredited this laboratory under the Hong Kong Laboratory Accreditation Scheme (HKLAS) for specific laboratory activities as listed in the HOKLAS Directory of Accredited Laboratories. The results shown in this report were generated by this laboratory in accordance with its terms of accreditation. This report shall not be reproduced without your written approval from this laboratory.

佳力高試驗中心有限公司
CASTCO TESTING CENTRE LTD.

香港特別行政區中環皇后大道中294號 294, Queen's Road, Central, Hong Kong, P.R.C.
Tel: 2877 2022, 2877 2138 Fax: 2877 2051 E-mail: castco@hoklas.com.hk Website: www.castco.com.hk

Test Certificate
Dimension and Mass Check on Cast Iron Spigot and Socket Drain Pipes and Fittings
(Based on BS437 : 1978 Clause 5)

Date of issue: 13-11-2004
Page: 1A of 1 page(s)
Castco LRN: DP241113-1424 DIM

Details as supplied by client
Client: Cheung Hing Foundry Limited Client's ref. no.: --
Contract no.: -- Job title: --
Sample description: 150 BS437 High Invert P Trap
Manufacturer: Cheung Hing Foundry Limited Brand: CHF
Remark: Sample Submitted by: Asia Development (1993) Ltd

Laboratory test result
Date sample received: 13-11-2004 Date of test: 23-11-2004
Dimension Check
Specimen no.: DP241113-1424

Dimensions	BS requirement from Spigot	Product requirement from code no. CH 191A	Measured mean value
A	--	425mm	424.6mm
B	--	218mm	211.2mm
C	--	258mm	254.2mm
E (H80) ± 24mm	--	240mm	240.2mm
F (H80) ± 90mm	--	94mm	94.5mm
S	--	83mm	85.0mm
X (H80) ± 150mm	--	150mm	151.5mm
X1 (H80) ± 195mm	--	191mm	190.2mm
B	--	93°	94.3°

Remarks: 1. Test result relates only to the specimen tested.
2. This page of report supersedes page 1A of previous test certificate of Castco LRN: DP241113-1424 DIM.

Checked by: Approved signature:
W.K. LEUNG
KEITH CHOI
Eng. MICE, MIBQE
Laboratory Engineer

Hong Kong Accreditation Service (HKAS) has accredited this laboratory under the Hong Kong Laboratory Accreditation Scheme (HOKLAS) for specific laboratory activities as listed in the HOKLAS Directory of Accredited Laboratories. The results shown in this report were determined by this laboratory in accordance with its terms of accreditation. This report shall not be reproduced unless with prior written approval from this laboratory.

佳力高試驗中心有限公司
CASTCO TESTING CENTRE LTD.

香港特別行政區中環皇后大道中294號 294, Queen's Road, Central, Hong Kong, P.R.C.
Tel: 2877 2022, 2877 2138 Fax: 2877 2051 E-mail: castco@hoklas.com.hk Website: www.castco.com.hk

Test Certificate
Hydrostatic Test of Cast Iron Spigot and Socket Drain Pipes and Fittings
(BS437 : 1978 Clause 7)

Date of issue: 15-12-2004
Page: 1A of 1 page(s)
Castco LRN: DP241113-1424 HYD

Details as supplied by client
Client: Cheung Hing Foundry Limited Client's ref. no.: --
Contract no.: -- Job title: --
Description of pipe:
Nominal bore: 150mm Length: -- Type: High Invert P Trap
Brand name: CHF (Diamond)

Delivery date: -- Manufacturer: Cheung Hing Foundry Limited Sample Submitted by: Asia Development (1993) Ltd

Laboratory Test Result
Date received: 13-11-2004 Date of test: 29-11-2004

Specimen no.	DP241113-1424
Actual internal hydrostatic pressure apply	170 kPa
Sustain period (min)	0.5
Test result	Passed

Remarks: 1. Test results relate only to the specimen tested.
2. This report supersedes previous test certificate of Castco LRN: DP241113-1424 HYD.

Checked by: Certified by:
W.K. LEUNG
PETER K.F. CHOI
B.Sc., C. Eng., MICE, MIBQE
Registered Professional Engineer

Hong Kong Accreditation Service (HKAS) has accredited this laboratory under the Hong Kong Laboratory Accreditation Scheme (HOKLAS) for specific laboratory activities as listed in the HOKLAS Directory of Accredited Laboratories. The results shown in this report were determined by this laboratory in accordance with its terms of accreditation. This report shall not be reproduced unless with prior written approval from this laboratory.

佳力高試驗中心有限公司
CASTCO TESTING CENTRE LTD.

香港特別行政區中環皇后大道中294號 294, Queen's Road, Central, Hong Kong, P.R.C.
Tel: 2877 2022, 2877 2138 Fax: 2877 2051 E-mail: castco@hoklas.com.hk Website: www.castco.com.hk

Test Certificate
Dimension and Mass Check on Cast Iron Spigot and Socket Drain Pipes and Fittings
(Based on BS437 : 1978 Clause 5)

Date of issue: 01-12-2005
Page: 1A of 1 page(s)
Castco LRN: DP250826-0323 DIM

Details as supplied by client
Client: Cheung Hing Foundry Limited Client's ref. no.: --
Contract no.: -- Job title: --
Sample description: 225mm x 225mm x 93° Equal Tee with Access Door
Manufacturer: Cheung Hing Foundry Limited Brand: CHF
Remark: Sample Submitted by: Asia Development (1993) Ltd

Laboratory test result
Date sample received: 28-08-2005 Date of test: 12-09-2005
Dimension Check
Specimen no.: DP250826-0323

Dimensions	Product requirement from code no. TAD22323B	Measured mean value
A	220mm	219.5mm
B	250mm	225.5mm
C	250mm	248.5mm
R	221mm	221.2mm
F	221mm	221.0mm
F	102mm	102.5mm
Z1	102mm	104.0mm
X	225mm	224.0mm
X1	277mm	277.0mm
Y	225mm	224.3mm
Y1	277mm	277.5mm
B	93°	93°

Remarks: 1. Test result relates only to the specimen tested.
2. This report supersedes previous test certificate of Castco LRN: DP250826-0323 DIM.

Checked by: Approved signature:
W.K. LEUNG
W.K. LEE
B.Sc., C. Eng., MICE, MIBQE
Registered Professional Engineer
General Manager

Hong Kong Accreditation Service (HKAS) has accredited this laboratory under the Hong Kong Laboratory Accreditation Scheme (HOKLAS) for specific laboratory activities as listed in the HOKLAS Directory of Accredited Laboratories. The results shown in this report were determined by this laboratory in accordance with its terms of accreditation. This report shall not be reproduced unless with prior written approval from this laboratory.

佳力高試驗中心有限公司
CASTCO TESTING CENTRE LTD.

香港特別行政區中環皇后大道中294號 294, Queen's Road, Central, Hong Kong, P.R.C.
Tel: 2877 2022, 2877 2138 Fax: 2877 2051 E-mail: castco@hoklas.com.hk Website: www.castco.com.hk

Test Certificate
Hydrostatic Test of Cast Iron Spigot and Socket Drain Pipes and Fittings
(BS437 : 1978 Clause 7)

Date of issue: 12-10-2005
Page: 1 of 1 page(s)
Castco LRN: DP250826-0323 HYD

Details as supplied by client
Client: Cheung Hing Foundry Limited Sample Submitted by: Asia Development (1993) Ltd
Contract no.: -- Job title: --
Description of pipe:
Nominal bore: 225mm x 225mm Length: -- Type: 90° Equal Tee with Access Door
Brand name: CHF

Delivery date: --

Laboratory Test Result
Date received: 01-09-2005 Date of test: 13-09-2005

Specimen no.	DP250826-0323
Actual internal hydrostatic pressure apply	170 kPa
Sustain period (min)	0.5
Test result	Passed

Remarks: 1. Test results relate only to the specimen tested.

Checked by: Certified by:
W.K. LEUNG
W.K. LEE
B.Sc., C. Eng., MICE, MIBQE
Registered Professional Engineer
General Manager

Hong Kong Accreditation Service (HKAS) has accredited this laboratory under the Hong Kong Laboratory Accreditation Scheme (HOKLAS) for specific laboratory activities as listed in the HOKLAS Directory of Accredited Laboratories. The results shown in this report were determined by this laboratory in accordance with its terms of accreditation. This report shall not be reproduced unless with prior written approval from this laboratory.



Preserve Environment, Use Cast Iron Products

IMPORTANT NOTE

1. Not to scale

All drawings are not to scale and are for reference only. Users must refer to the actual product for actual design, dimension and pattern.
Cheung Hing Foundry (HK) Limited. reserves the rights to supply products with design, dimension and pattern slightly different from those shown in this catalog.
2. Colors

The colors of the products shown in this catalog may be slightly different from the actual products due to the difference in colors between printing and the paint used in manufacture.
3. Changes in market demand

Although CHF takes care to ensure that the information given in this catalog is as accurate as possible at the time of publication, it reserves the rights to make changes or to discontinue individual products at its discretion as a result of developments in the industry, changes in market demand and other changes in circumstances.
4. Different from British Standard

As a result of changes in general demand from the local drainage and plumbing industries, the designs and dimensions of some products may differ in some respects from those specified in the British Standard. It is advisable to take these factors into consideration when designing drainage or pipework systems.
According to BS437:1978, there is a permissible deviation of +/- 12.5mm on the length of all pipes and fittings.
5. Installation instructions

Users must follow the installation instructions.
All castings should benefit from proper operation and maintenance.
6. Casting

The physical structure of cast iron may change during and/or after the process of smelting, therefore, some variance in the dimensions of products is anticipated.

All rights reserved.

It is unlawful to copy or extract the whole or part of the materials from this catalog without the written consent of Cheung Hing Foundry (HK) Limited.

August, 2011 Edition



CHEUNG HING FOUNDRY (HK) LIMITED

Address : 299, Pak Sha Tsuen,
Kung Um Road, Yuen Long, Hong Kong
Tel : (852) 2447-1262 Fax : (852) 2447-0198

祥興鑄鐵有限公司

地址：香港 元朗公庵路 白沙村 299 號
Email : chf@chfhk.com http://www.chfhk.com