



# Eco-Cast Iron

Double-Triangular & Desilting Manhole Cover and Frame,  
Road Gully Gratings/Kerb Overflow Weirs / Double Seal Manhole Cover and Frame

## 環保雙止口沙井蓋板 ATC, E&M, TCS 蓋板 DS1034B • 750X900X165 雙三角蓋板

“General Specification for Civil Engineering Works”

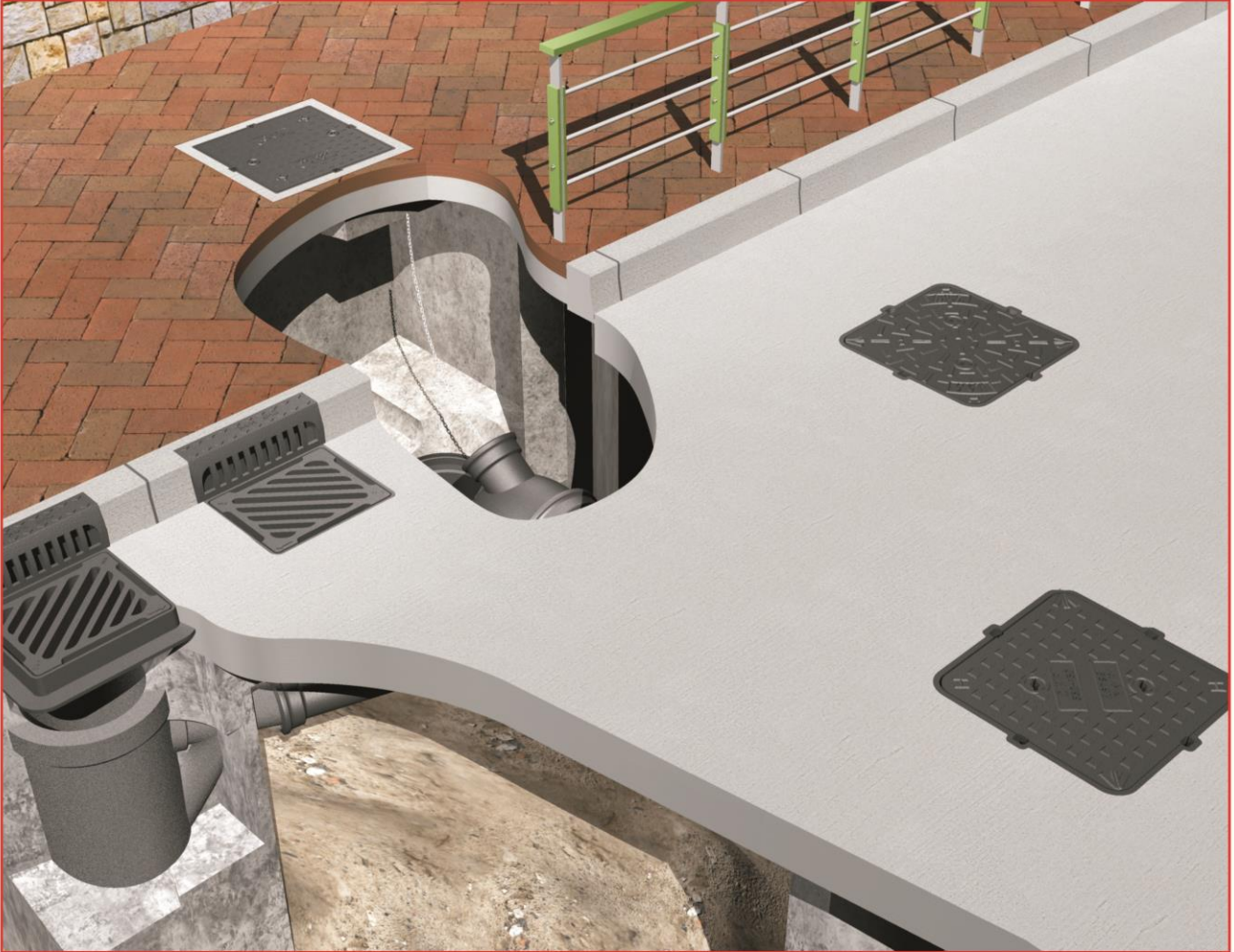

Cast Iron Double-Triangular & Desilting Manhole Cover and Frame  
生鐵雙三角沙井蓋板

Eco-Cast Iron Double-Seal & Desilting Manhole Cover and Frame  
環保生鐵雙止口沙井蓋板

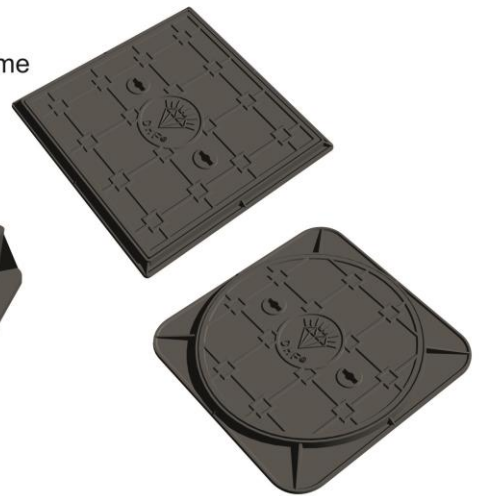

祥興鑄鐵有限公司  
CHEUNG HING FOUNDRY (HK) LIMITED



# Eco-Cast Iron Double Seal Terminal Manhole Cover for sewers



## 環保生鐵雙止口平面沙井蓋板

BS EN 124:1994

General Specification for Civil Engineering Works

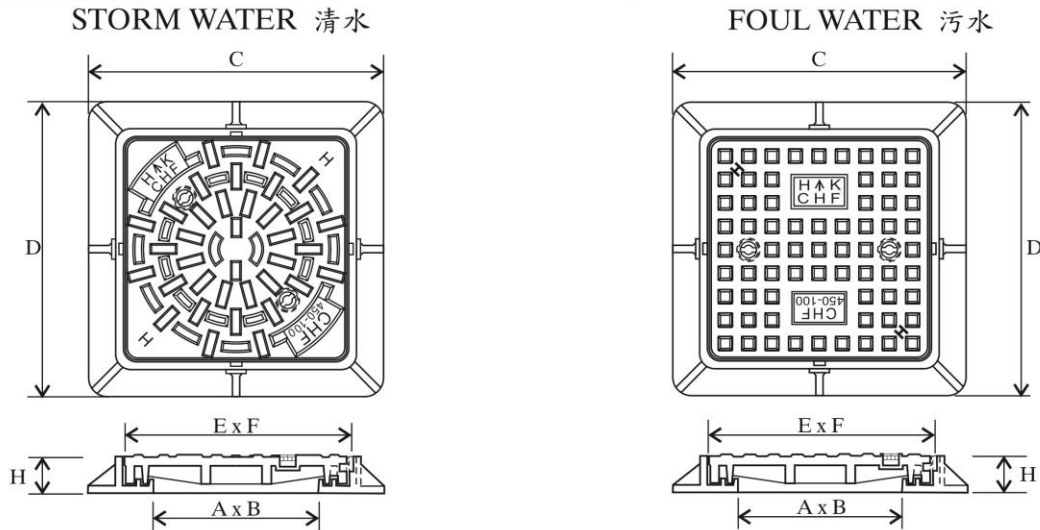

### Technical Specification

Item 序號	Code Number 貨號	Clear Opening 內孔 A x B mm x mm	Over Base Size 底框外皮 C x D mm x mm	Cover Size 蓋面尺寸 E x F mm x mm	Height 高度 H mm	Type 款式 清水 Storm Water/ 污水 Foul Water	Class	G.S. Grade 級別	DSD Drawing No. 渠務署 圖則編號	Type 類型
1	MAE180/400-45B	180 X 400	330 X 550	300 X 520	45	FW		L	DS 1059B	MC2-40/18A
2	MAA0450-045A	450 X 450	620 X 620	580 X 580	45	SW		L	DS 1042B	MC2-45/45B
3	MAA0450-045B	450 X 450	620 X 620	580 X 580	45	FW		L	DS 1038B	MC2-45/45A
4	MAA0450-100A	450 X 450	810 X 810	610 X 610	100	SW	C	H	DS 1040B	MA2-45/45B
5	MAA0450-100B	450 X 450	810 X 810	610 X 610	100	FW	C	H	DS 1036B	MA2-45/45A
6	MAA0450-040A	450 X 450	625 X 625	520 X 520	40	SW	A	-	-	-
7	MAA0450-040B	450 X 450	625 X 625	520 X 520	40	FW	A	-	-	-
8	MAA0550-050A	550 X 550	710 X 710	630 X 630	50	SW	A	-	-	-
9	MAA0550-050B	550 X 550	710 X 710	630 X 630	50	FW	A	-	-	-
10	MAA0550-100A	550 X 550	770 X 770	655 X 655	100	SW	B	M		
11	MAA0550-100B	550 X 550	770 X 770	655 X 655	100	FW	B	M		
12	MAA0550-125A	550 X 550	790 X 970	659 X 659	125	SW	C	-		
13	MAA0550-125B	550 X 550	790 X 790	659 X 659	125	FW	C	-		
14	MAA0550-150A	550 X 550	800 X 800	665 X 665	150	SW	D	H		
15	MAA0550-150B	550 X 550	800 X 800	665 X 665	150	FW	D	H		
16	MAA0600-050A	600 X 600	780 X 780	690 X 690	50	SW	A	L		
17	MAA0600-050B	600 X 600	780 X 780	690 X 690	50	FW	A	L		
18	MAA0600-100A	600 X 600	950 X 950	775 X 775	100	SW	B			
19	MAA0600-100B	600 X 600	950 X 950	775 X 775	100	FW	B			
20	MAA0600-150A	600 X 600	900 X 900	755 X 755	150	SW	C			
21	MAA0600-150B	600 X 600	900 X 900	755 X 755	150	FW	C			
22	MAA0675-150A	675 X 675	935 X 935	800 X 800	150	SW	C			
23	MAA0675-150B	675 X 675	935 X 935	800 X 800	150	FW	C			
24	MAB750/900-150A	750 X 900	1100X1250	925 X 1075	150	SW	C	H		
25	MAB750/900-150B	750 X 900	1100X1250	925 X 1075	150	FW	C	H		

Note :The above dimensions are for reference only. Please refer to the actual products.



祥興鑄鐵有限公司  
CHEUNG HING FOUNDRY (HK) LIMITED



## 環保生鐵雙止口平面沙井蓋板

### General Specification for Civil Engineering Works

**Standard:** “General Specification for Civil Engineering Works”

Published by the Civil Engineering and Development Department  
The Government of the HKSAR.

Grade	Test load (t)
<b>Medium duty (M)</b>	5
<b>Heavy duty (H)</b>	20

Type of manhole cover and frame	Grade	Test requirements	
		Diameter of test block (mm)	Test load (t)
Double seal terminal sewer manhole cover Type MA2-45/45A & B	<b>Heavy duty (H)</b>	300	20
Type MC2-45/45A & B	<b>Light duty (L)</b>	Symbol GJL-150 of BS 1561	

**Standard:** **BSEN124:1994**

Class	Test load (kN)	Place of installation
<b>A</b>	15	Suitable for areas which can be used by pedestrians and pedal cyclists.
<b>B</b>	125	Suitable for footways, pedestrian areas and comparable areas, car parks or car parking decks.
<b>C</b>	250	Suitable for gully tops installed in the area of kerbside channels of roads which when measured from the kerb edge, extend a maximum of 0.5m into the carriageway and a maximum of 0.2m into the footway.
<b>D</b>	400	Suitable for carriageways of roads (including pedestrian streets), hard shoulders and parking areas, for all types of road vehicles.

**Functions:** The double-seal feature of the manhole covers and frames prevents foreign Materials from entering into the underground sewage system and also prevents the pungent smell and/or methane from getting out of the underground sewage system.

**Type:** **SW** for storm water (with circumscribed raised stubs on the cover)  
**FW** for foul water (with square raised stubs on the cover)

**Material:** Cast Iron Symbol EN GJL-150 of BS EN 1561 : 1997





# Eco-Cast Iron Double Seal Terminal Manhole Cover for sewers



## 環保生鐵雙止口平面沙井蓋板



HOKLAS Endorsed Test Certificates

### General Specification for Civil Engineering Works

**CASTCO** 佳力高試驗中心有限公司  
CASTCO TESTING CENTRE LTD.

香港粉嶺安樂街33號 33, On Kai Street, Fanling, Hong Kong. Tel: 2677 2138  
香港粉嶺安樂街29A號 29A, On Chuen Street, Fanling, Hong Kong. Fax: 2677 0351  
E-mail: castco@netvigator.com Website: www.castco.com.hk

**Test Certificate**  
Mass Determination and Loading Test to Cast Iron Drainage Goods  
(Tested to G.S. for C.E. Works : 1992 : Cl. 5.9(4)(2) and Appendix 5.3)

Date of issue: 08-11-2006  
Page 1 of 1 page  
Castco Lab. Ref. No.: DP261104-0746 MISCEL

*Details as supplied by client*

Client: Cheung Hing Foundry Ltd. Client's Ref. No.: --  
Contract No.: -- Title: --  
Sample Description: 450 Clear Opening x 100 Height Cast Iron Double Seal Manhole Cover & Frame  
Grade: heavy duty

**Laboratory Test Result**  
Date received: 04-11-2006 Date tested: 06-11-2006

Dia. of bearing block : 300 mm

Specimen No.	Specimen Description	Grade claimed by client	Measured mass (kg)	Loading Test (Test load maintained for 30 sec)		Observation
				Test load (kN)	Loading test result (passed/failed)	
DP261104-0746	450 Clear Opening x 100 Height Cast Iron Double Seal Manhole Cover & Frame	Heavy duty	--	196.2 (20 tonnes)	Passed	N/V

### BSEN 124:1994

**CASTCO** 佳力高試驗中心有限公司  
CASTCO TESTING CENTRE LTD.

香港粉嶺安樂街33號 33, On Kai Street, Fanling, Hong Kong. Tel: 2677 2138  
香港粉嶺安樂街29A號 29A, On Chuen Street, Fanling, Hong Kong. Fax: 2677 0351  
E-mail: castco@netvigator.com Website: www.castco.com.hk

**Test Certificate**  
Mass Determination & Loading Test of Manhole Covers, Gully Gratings & Kerb Overflow Weirs  
(Tested to BS EN 124 : 1994, Cl. 4 (AMD 8587))

Date of issue: 26-10-2006  
Page 1 of 1 page  
Castco Lab. Ref. No.: DP260925-0624 MISCEL

*Details as supplied by client*

Client: Cheung Hing Foundry Ltd. Client's Ref. No.: --  
Contract No.: -- Title: --  
Sample Description: 550 Clear Opening x 65 Height Cast Iron Double Seal Manhole Cover & Frame  
Class: A15

**Laboratory Test Result**  
Date Received: 25-09-2006 Date Tested: 30-09-2006

Specimen No.	Specimen Description	Clear opening (mm)	Size of test block (mm)	Measurement of permanent set			Application of the test load (Test load maintained for 30 sec.)		Observation
				2/3 of the test load applied (kN)	Permanent set test result (mm)	Permanent set test result (mm)	Load applied (kN)	Loading test result	
DP260925-0624	--	--	--	--	--	--	15	Passed	N/V

**Remark:**  
1. Legend: FC - Fracture at cover FF - Fracture at frame NV - No visible fracture.  
2. Test results relate only to the specimen tested.  
3. At client's request, measurement of permanent set was not performed.

Checked by: K. N. SIT Approved signature: KEITH CHOI  
Engr. (M) (Struct. Eng.) (M) (Struct. Eng.) Engr. (M) (Struct. Eng.) (M) (Struct. Eng.)

**CASTCO** 佳力高試驗中心有限公司  
CASTCO TESTING CENTRE LTD.

香港粉嶺安樂街33號 33, On Kai Street, Fanling, Hong Kong. Tel: 2677 2138  
香港粉嶺安樂街29A號 29A, On Chuen Street, Fanling, Hong Kong. Fax: 2677 0351  
E-mail: castco@netvigator.com Website: www.castco.com.hk

**Test Certificate**  
Mass Determination & Loading Test of Manhole Covers, Gully Gratings & Kerb Overflow Weirs  
(Tested to BS EN 124 : 1994, Cl. 4 (AMD 8587))

Date of issue: 19-06-2006  
Page 1 of 1 page  
Castco Lab. Ref. No.: DP260610-0602 MISCEL

*Details as supplied by client*

Client: Cheung Hing Foundry Ltd. Client's Ref. No.: --  
Contract No.: -- Title: --  
Sample Description: 550 Clear Opening x 100 Height Cast Iron Double Seal Manhole Cover & Frame  
Class: B125

**Laboratory Test Result**  
Date Received: 16-06-2006 Date Tested: 13-06-2006

Specimen No.	Specimen Description	Clear opening (mm)	Size of test block (mm)	Measurement of permanent set			Application of the test load (Test load maintained for 30 sec.)		Observation
				2/3 of the test load applied (kN)	Permanent set test result (mm)	Permanent set test result (mm)	Load applied (kN)	Loading test result	
DP260610-0602	--	--	--	--	--	--	125	Passed	N/V

**Remark:**  
1. Legend: FC - Fracture at cover FF - Fracture at frame NV - No visible fracture.  
2. Test results relate only to the specimen tested.  
3. At client's request, measurement of permanent set was not performed.

Checked by: W. K. LEUNG Approved signature: K. YEO  
Engr. (M) (Struct. Eng.) (M) (Struct. Eng.) Engr. (M) (Struct. Eng.) (M) (Struct. Eng.)

**CASTCO** 佳力高試驗中心有限公司  
CASTCO TESTING CENTRE LTD.

香港粉嶺安樂街33號 33, On Kai Street, Fanling, Hong Kong. Tel: 2677 2138  
香港粉嶺安樂街29A號 29A, On Chuen Street, Fanling, Hong Kong. Fax: 2677 0351  
E-mail: castco@netvigator.com Website: www.castco.com.hk

**Test Certificate**  
Mass Determination & Loading Test of Manhole Covers, Gully Gratings & Kerb Overflow Weirs  
(Tested to BS EN 124 : 1994, Cl. 4 (AMD 8587))

Date of issue: 26-10-2006  
Page 1 of 1 page  
Castco Lab. Ref. No.: DP260925-0625 MISCEL

*Details as supplied by client*

Client: Cheung Hing Foundry Ltd. Client's Ref. No.: --  
Contract No.: -- Title: --  
Sample Description: 550 Clear Opening x 125 Height Cast Iron Double Seal Manhole Cover & Frame  
Class: C250

**Laboratory Test Result**  
Date Received: 25-09-2006 Date Tested: 30-09-2006

Specimen No.	Specimen Description	Clear opening (mm)	Size of test block (mm)	Measurement of permanent set			Application of the test load (Test load maintained for 30 sec.)		Observation
				2/3 of the test load applied (kN)	Permanent set test result (mm)	Permanent set test result (mm)	Load applied (kN)	Loading test result	
DP260925-0625	--	--	--	--	--	--	250	Passed	N/V

**Remark:**  
1. Legend: FC - Fracture at cover FF - Fracture at frame NV - No visible fracture.  
2. Test results relate only to the specimen tested.  
3. At client's request, measurement of permanent set was not performed.

Checked by: K. N. SIT Approved signature: KEITH CHOI  
Engr. (M) (Struct. Eng.) (M) (Struct. Eng.) Engr. (M) (Struct. Eng.) (M) (Struct. Eng.)

**CASTCO** 佳力高試驗中心有限公司  
CASTCO TESTING CENTRE LTD.

香港粉嶺安樂街33號 33, On Kai Street, Fanling, Hong Kong. Tel: 2677 2138  
香港粉嶺安樂街29A號 29A, On Chuen Street, Fanling, Hong Kong. Fax: 2677 0351  
E-mail: castco@netvigator.com Website: www.castco.com.hk

**Test Certificate**  
Mass Determination & Loading Test of Manhole Covers, Gully Gratings & Kerb Overflow Weirs  
(Tested to BS EN 124 : 1994, Cl. 4 (AMD 8587))

Date of issue: 26-10-2006  
Page 1 of 1 page  
Castco Lab. Ref. No.: DP260925-0626 MISCEL

*Details as supplied by client*

Client: Cheung Hing Foundry Ltd. Client's Ref. No.: --  
Contract No.: -- Title: --  
Sample Description: 550 Clear Opening x 150 Height Cast Iron Double Seal Manhole Cover & Frame  
Class: D400

**Laboratory Test Result**  
Date Received: 25-09-2006 Date Tested: 30-09-2006

Specimen No.	Specimen Description	Clear opening (mm)	Size of test block (mm)	Measurement of permanent set			Application of the test load (Test load maintained for 30 sec.)		Observation
				2/3 of the test load applied (kN)	Permanent set test result (mm)	Permanent set test result (mm)	Load applied (kN)	Loading test result	
DP260925-0626	--	--	--	--	--	--	400	Passed	N/V

**Remark:**  
1. Legend: FC - Fracture at cover FF - Fracture at frame NV - No visible fracture.  
2. Test results relate only to the specimen tested.  
3. At client's request, measurement of permanent set was not performed.

Checked by: K. N. SIT Approved signature: KEITH CHOI  
Engr. (M) (Struct. Eng.) (M) (Struct. Eng.) Engr. (M) (Struct. Eng.) (M) (Struct. Eng.)



祥興鑄鐵有限公司  
CHEUNG HING FOUNDRY (HK) LIMITED



# Eco-Cast Iron Double Seal Terminal Manhole Cover for sewers



## 環保生鐵雙止口平面沙井蓋板

General Specification for Civil Engineering Works

450mm Round Cover for Storm Water

450mm Square Cover for Foul Water

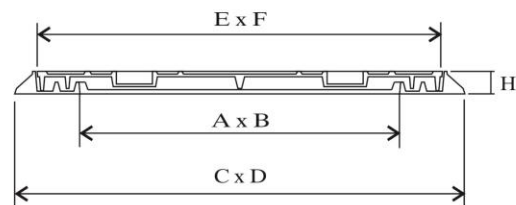
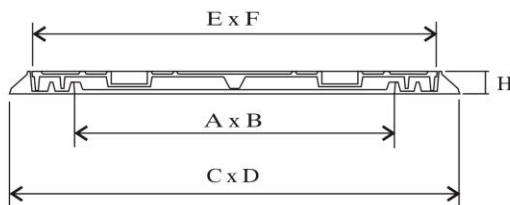
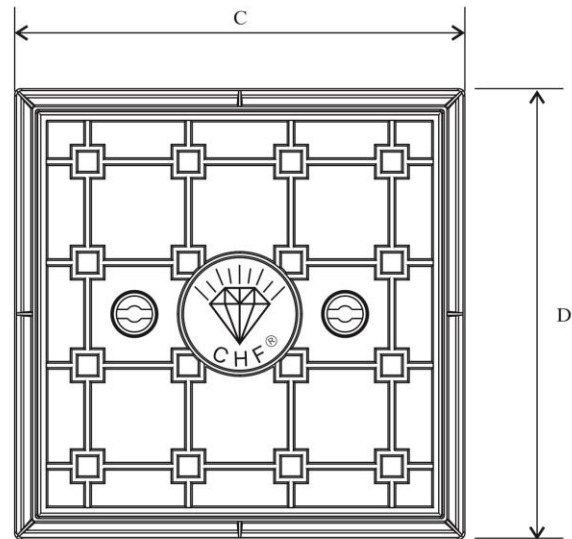
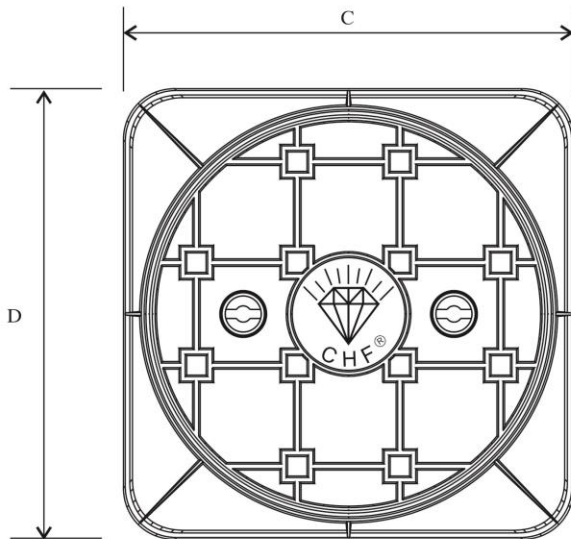

### Technical Specification:

Item 序號	Code Number 貨號	Clear Opening 內孔 A x B mm x mm	Over Base Size 底框外皮 C x D mm x mm	Cover Size 蓋面尺寸 E x F mm x mm	Height 高度 H mm	Type 款式 清水 Storm Water/ 污水 Foul Water	Material 材質
1	MBC450N	Ø 355	500 x 500	Ø 450	25	SW	Cast Iron
2	MBA450P	355 x 355	500 x 500	450 x 450	25	FW	Cast Iron

Note :The above dimensions are for reference only. Please refer to the actual products.



**CHEUNG HING FOUNDRY (HK) LIMITED**  
Address : 299, Pak Sha Tsuen,  
Kung Um Road, Yuen Long, Hong Kong  
Tel : (852) 2447-1262 Fax : (852) 2447-0198

**祥興鑄鐵有限公司**  
地址：香港 元朗公庵路 白沙村 299 號  
Email : chf@chfhk.com http://www.chfhk.com



# Eco-Cast Iron Single Seal ATC DRAW PIT - HEAVY DUTY



## 環保生鐵單止口平面沙井蓋板

HIGHWAYS DEPARTMENT  
DRAWING No. H2162A

General Specification for Civil Engineering Works

(Heavy Duty)

600X600 clear opening X100 height cover & frame (ATC / TCS / E&M)

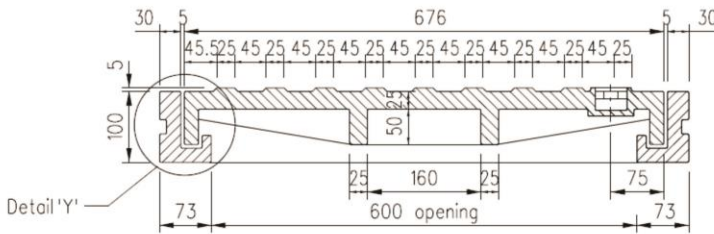

SECTION G - G

Bearing faces on cover and frame machined to same level. So that all four corners are in close contact

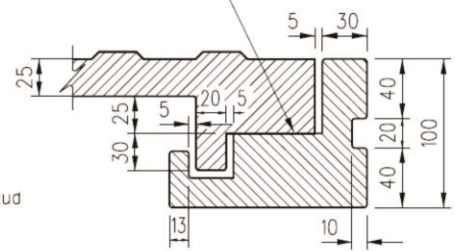

SECTION H - H

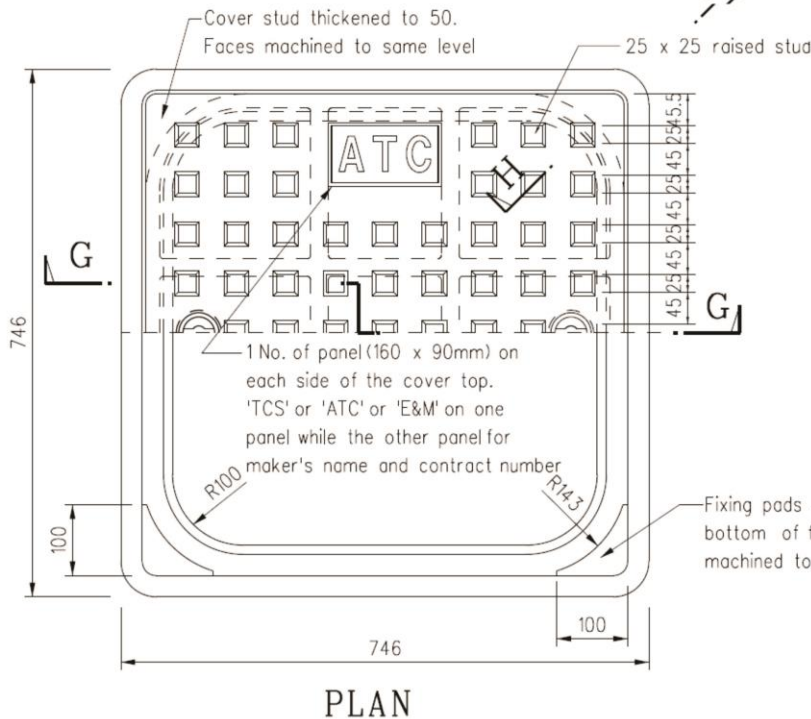

PLAN

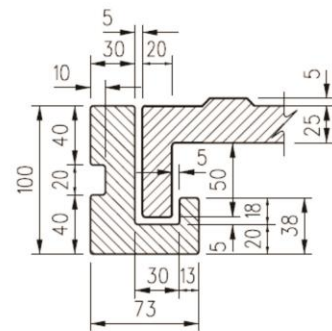

DETAIL 'Y'

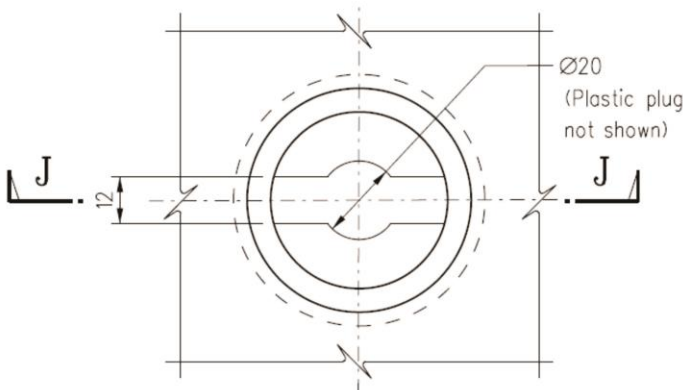

PLAN OF KEY HOLE

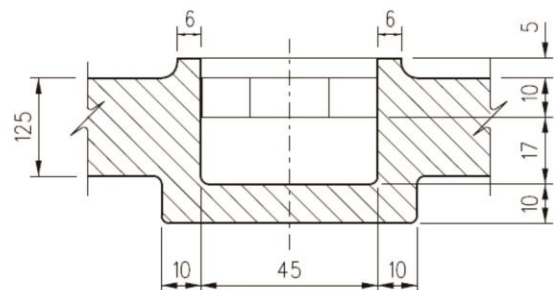

SECTION J - J



**CHEUNG HING FOUNDRY (HK) LIMITED**  
Address : 299, Pak Sha Tsuen,  
Kung Um Road, Yuen Long, Hong Kong  
Tel : (852) 2447-1262 Fax : (852) 2447-0198

**祥興鑄鐵有限公司**

地址：香港 元朗公庵路 白沙村 299 號  
Email : chf@chfhk.com http://www.chfhk.com

750X900mm 內孔165mm高雙三角生鐵沙井蓋板

750X900mm Clear Opening 165mm Height Double triangular Cast iron Manhole Cover and Frame

**DS1034B**

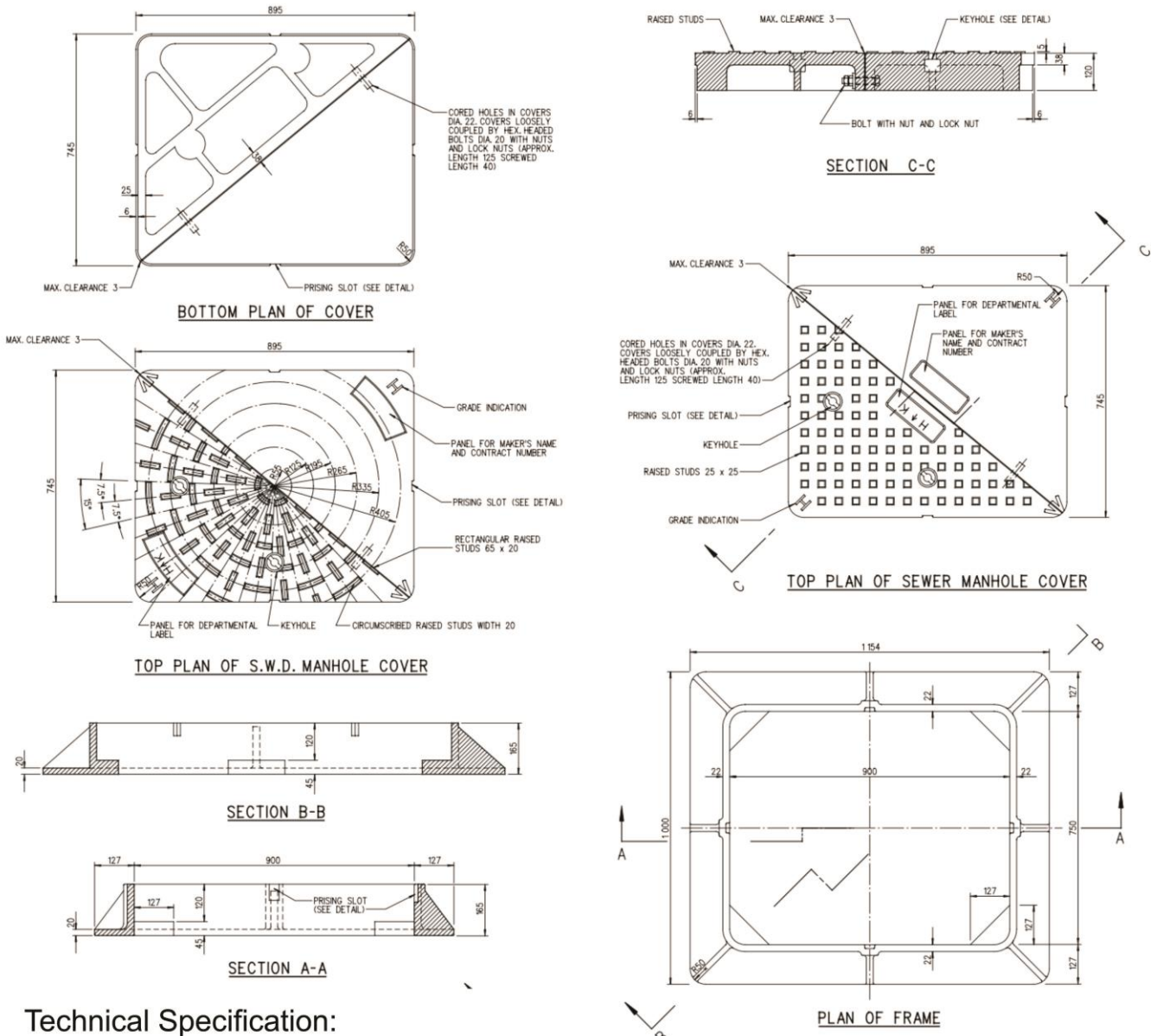

### Technical Specification:

Item 序號	Code Number 編號	Clear Opening 內孔 mm	Over Base Size 底框外皮 C x D mm x mm	Height 高度 H mm	Type 款式 清水 Storm Water/ 污水 Foul Water	Grade 級別 H=Heavy Duty 重磅
1	MAF750/900-165A	750 X 900	1000 X 1154	165	SW	H
2	MAF750/900-165B	750 X 900	1000 X 1154	165	FW	H

Note :The above dimensions are for reference only. Please refer to the actual products.